

ANTI-ROLL GYRO STABILIZER

INSTALLATION AND USE MANUAL

EN

page 3



mc² X7
QUICK GYRO

ANTI-ROLL GYRO STABILIZER

INSTALLATION AND USE MANUAL

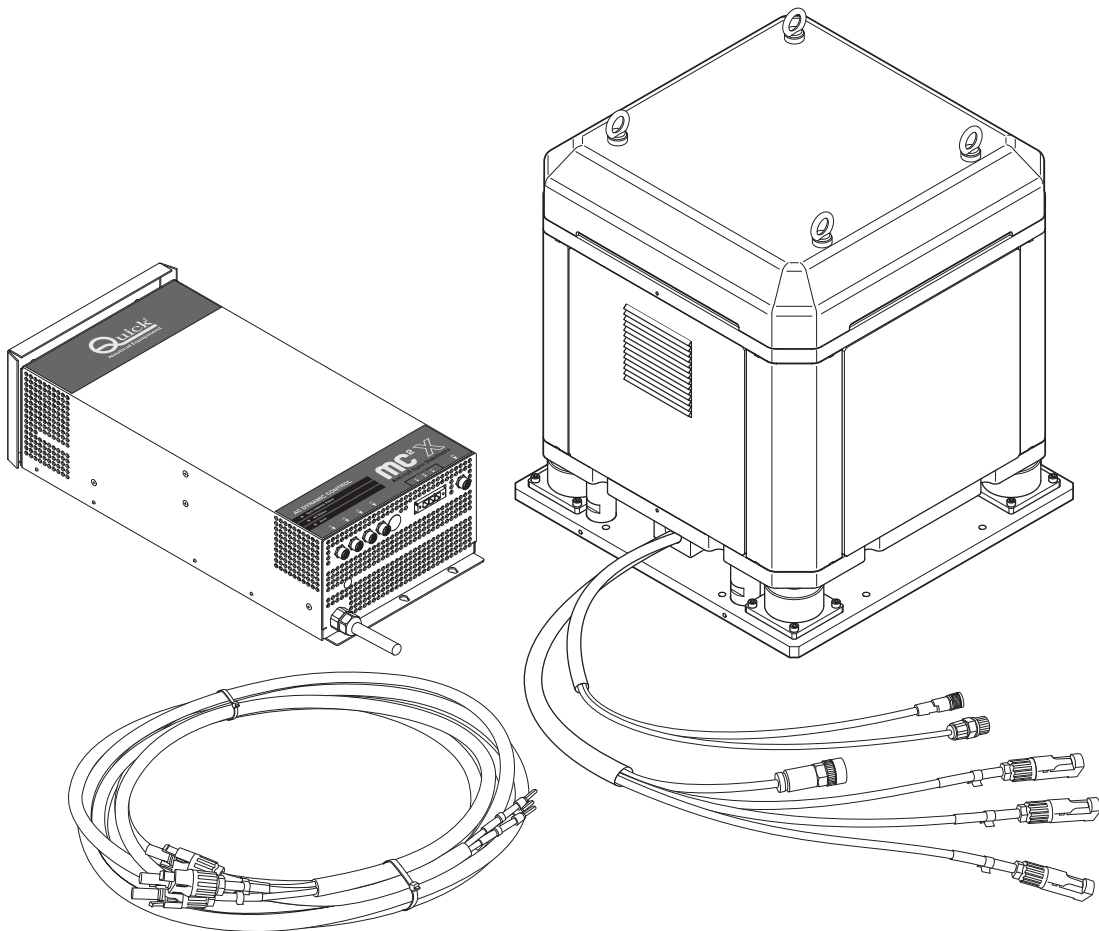

STABILIZATION PRINCIPLES

The stability of a boat is influenced by several factors, such as the hull shape, the displacement, the mass distribution, the gyro installation position and sea conditions.

What is rolling?

Rolling is the oscillation of the boat around its longitudinal axis. Since vessels are much longer than larger, as a consequence-side oscillation can be felt much more.

The rolling motion is the most dangerous since it affects the vessel stability and it's there for the one on which the first reduction studies have been carried out. More overside rolling is the main cause of sea sickness, especially in case of long waves.

THE CORE OF BOAT'S STABILITY CONCEPT

In order to stabilize a boat, its center of gravity must be under the meta centre. In fact, the higher is its metacentric height, the more stable is the boat.

THE CENTRE OF THRUST

BEFORE TALKING ABOUT STABILITY, WE NEED TO UNDERSTAND HOW THE THRUST'S CENTRE MOVES, ESPECIALLY DURING THE ROLLING MOTION.

At equilibrium, the weight of the boat applies on (G), the Archimedes thrust applies on (C).

Throughout the rolling motion, the hull turns and the centre of thrust (C) constantly moves. Crossing the buoyancy force's line of action with the longitudinal plane of symmetry, we can find a new point called metacentre (M), located above the centre of gravity.

The distance between centre of gravity (G) and the metacentre (M) is called metacentric height (GM) which is very important for a boat's stability, since it represents the righting lever.

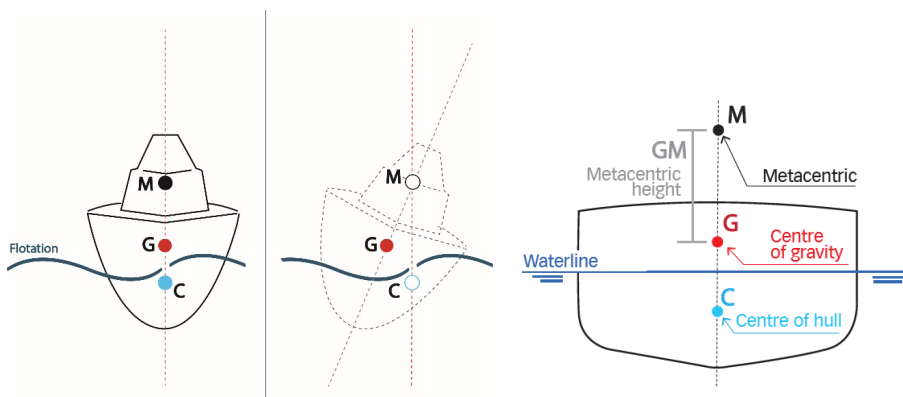

Some basic definitions:

CENTRE OF GRAVITY

point of application of the resultant torque of all the boat's weight and cargo.

CENTRE OF THRUST (CENTRE OF HULL)

the midpoint where is applied the resultant of all the forces that water thrust applies on the hull.

METACENTRE the point of intersection of thrust force's projection and the vertical line that pass through the initial centre of buoyancy and the centre of gravity.

HOW A QUICK GYRO STABILIZER IS MADE

Quick MC2 gyro stabilizer has been designed for all types of boats, with the goal of improving on board comfort level by reducing the roll amplitude in presence of waves.

Gyroscopic stabilization takes place when a fly wheel, rotating around its rotation axis, due to external causes (boat rolling) also rotates around its precession axis, perpendicular to the first, thus generating a stabilizing torque (gyroscopic effect).

The gyrostabilizer therefore opposes to the rolling movement by applying a stabilizing torque which opposes to the heeling torque originated from the waves.

THE CONCEPT OF ONBOARD COMFORT

The onboard comfort is affected by «motion sickness» or sea sickness in case of boats. This sickness results from and is amplified by specific conditions such as vibrations (like propulsion's, engines' etc), smells (such as fuel oil or diesel) and most of all by accelerations. Accelerations onboard result from the vertical and side motion of the boat, especially pitching motion (on which we can't take any action) and rolling motion (objective of the gyro stabilizer).

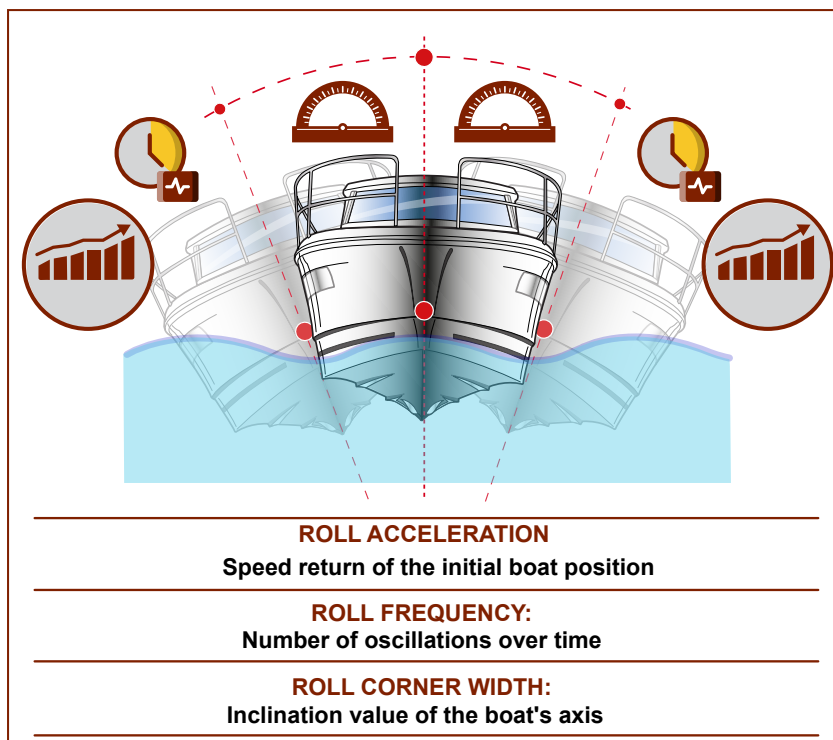
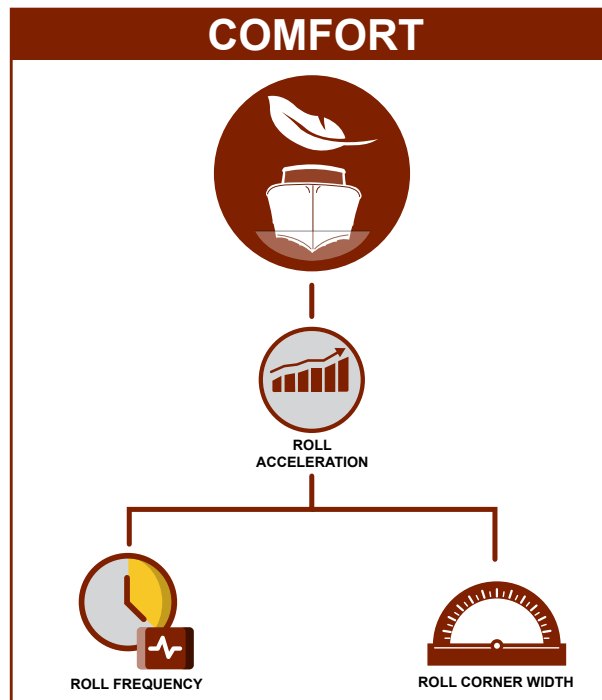



mc² X7
QUICK GYRO



Standard equipment and required accessories	Pag. 10
Premise	Pag. 4
Stabilization principles	Pag. 4
The core of boat's stability concept	Pag. 4
The centre of thrust	Pag. 4
How a quick gyro stabilizer made	Pag. 4
The concept of onboard comfort	Pag. 5
1 - Information about the product	Pag. 8
1.0 - Description	Pag. 8
1.2 - Technical data	Pag. 8
1.4 - Dimensions	Pag. 9
1.5 - Dimensions with base plate (optional)	Pag. 9
2 - Supplied parts	Pag. 11
2.0 - Package contains the following parts	Pag. 11
2.1 - Required accessory, not supplied with the stabilizer	Pag. 11
2.2 - Required components, not supplied with the stabilizer	Pag. 11
2.3 - Tools needed for installation	Pag. 11
3 - Introduction	Pag. 12
3.0 - General information	Pag. 12
3.1 - Preliminary technical checks	Pag. 12
4 - Safety	Pag. 13
4.0 - Precautions	Pag. 13
4.1 - Warnings	Pag. 13
4.2 - Personal protection equipment (PPE)	Pag. 14
4.3 - Stickers/labels on the stabilizer	Pag. 14
4.4 - Cases	Pag. 15
4.5 - Flywheel Rotation	Pag. 15
4.6 - Air output	Pag. 15
5 - Handling and Transportation	Pag. 16
5.0 - General instructions and precautions	Pag. 16
5.1 - Crate removal	Pag. 16
5.2 - Lifting the stabilizer	Pag. 17
6 - Housing	Pag. 18
6.0 - Structure and housing analysis	Pag. 18
6.1 - Environmental requirements	Pag. 18
6.2 - Water line	Pag. 18
6.3 - Installing a single stabilizer	Pag. 19
6.4 - Installation of multiple units on the same boat	Pag. 20
7 - Installation procedures	Pag. 21
7.0 - Support structure	Pag. 21
7.1 - Types of Underbody	Pag. 21
7.2 - Warnings	Pag. 21
7.3 - Planarity of installation	Pag. 22
7.4 - Stabilizer securing	Pag. 23
7.5 - Stabilizer securing with base plate (optional)	Pag. 24
7.6 - Fiberglass Support - Example 1	Pag. 25
7.7 - Fiberglass Support - Example 2	Pag. 26
7.8 - Brachet - Example 3	Pag. 27
7.9 - Brachet - Example 4	Pag. 28
8 - Electrical connection	Pag. 29
8.0 - Connection system devices	Pag. 29
8.1 - Devices dimensions	Pag. 30
8.2 - Connection diagram	Pag. 31
8.3 - Driver and stabilizer connection	Pag. 32
9 - Start-up	Pag. 33
9.0 - Introduction	Pag. 33
9.1 - Start-up instructions	Pag. 33
10 - Maintenance	Pag. 33
10.0 - Introduction	Pag. 33
10.1 - Warnings	Pag. 33
10.2 - Periodic maintenance	Pag. 34
10.3 - Annual maintenance	Pag. 35
10.4 - External Cleaning	Pag. 35
11 - Scrapping and Disposing	Pag. 36
11.0 - Scrapping	Pag. 36
11.1 - Disposing	Pag. 37
12 - Accessories	Pag. 38
Remote Control	Pag. 38
Remote Control Accessories	Pag. 38



1.0 - Description

The **MC²** series is the result of careful research, aimed at achieving highly competitive performances. The Quick® research and development laboratories have revolutionized the **MC²** series' concept of operation, by introducing technical solutions capable of guaranteeing greater safety, more comfort and much higher performances. The **MC²** series stabilizers are compact and functional.

Quick MC²X7 is useful and effective to improve comfort on board, but it does not eliminate the risks deriving from harsh atmospheric conditions.

1.1 - Main features

- Maximum performance
- Maximum protection
- Smart and compact design
- High installation flexibility
- Dynamic precession control
- Precession lock function from remote panel.
- Equipped with Quick® electric motors.
- Low noise emission.
- Overheating protection.
- Thermal protection.
- **MC²** Mobile App to record stabilizer performance (iOS and Andorid)
- **Reduced maintenance**

1.2 - Technical data

MODEL	MC²X7	MC²X7 LV
Rated speed (1)	4800 RPM	4800 RPM
Angular momentum (2)	2174 N·m·s	2174 N·m·s
Output torque (3)	6678 N·m	6678 N·m
Spool-up time to rated RPM	20 min	20 min
Spool-up time to stabilization	16 min	16 min
Power absorbed	1500 W max	1500 W max
AC Input voltage	90-240 Vac	90-120 Vac
Frequency	50-60 Hz	50-60 Hz
Noise output	< 70 dB	< 70 dB
Ambient air temperature	from -10°C to +55°C (14° F - 131° F)	from -10°C to +55°C (14° F - 131° F)
Weight	300 kg (661,4 lb)	300 kg (661,4 lb)

(1) Rated speed: flywheel speed (RPM: Revolutions per minute).

(2) Angular momentum: it quantifies the torque that is necessary to balance the system in the time unit (Newtons meter second).

(3) Output torque: torque generated by the rotor at rated speed (Newtons per meter).



1.3 - Power Absorbtion

MODEL MC ²	POWER ABSORBED [W]	220V	
		AMPERE 1F [A]	CIRCUIT BRAKER [A]
X7	1500	9	10

MODEL MC ²	POWER ABSORBED [W]	110V	
		AMPERE 1F [A]	CIRCUIT BRAKER [A]
X7 LV	1500	18	25

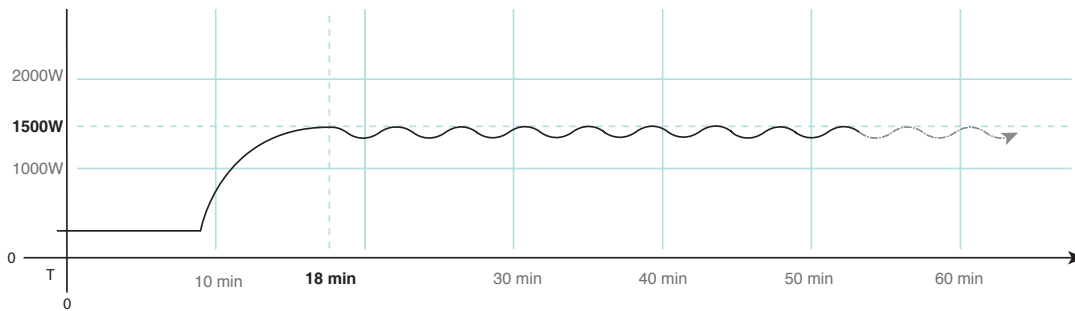

1.4 Dimensions

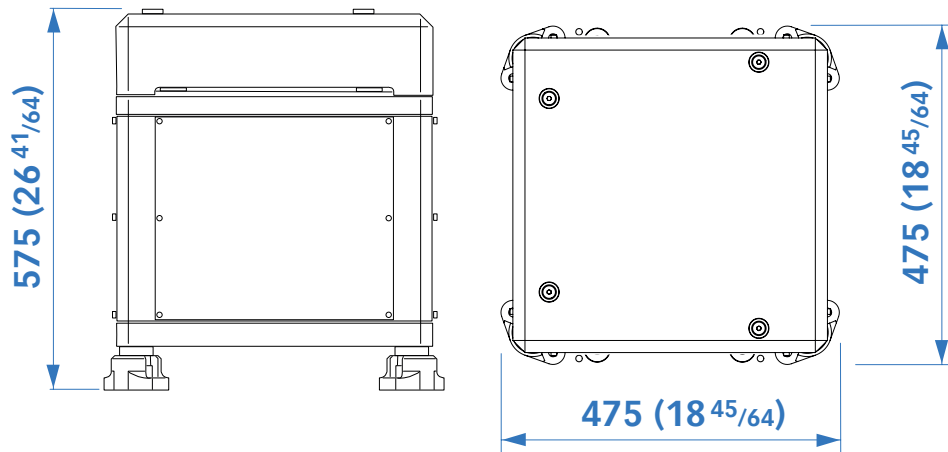

1.5 Dimensions with base plate (optional)

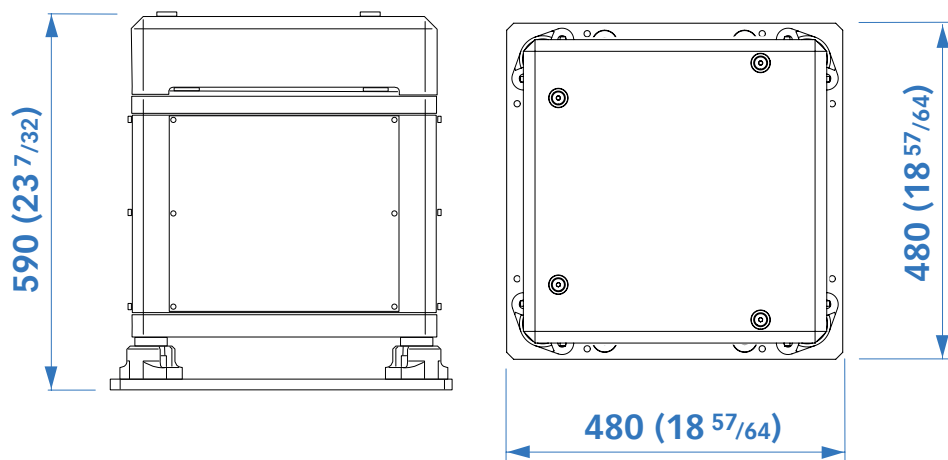



Standard Equipment Kit

mc² X7
QUICK GYRO

EN

Material included in the stabilizer's packaging

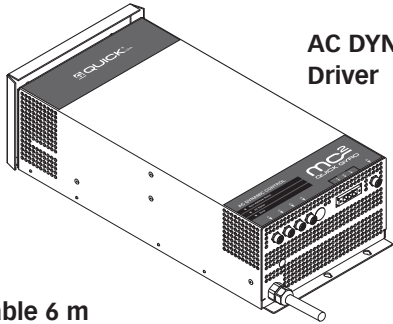

AC DYNAMIC CONTROL MC²
Driver

Power cable 6 m
stabilizer → driver

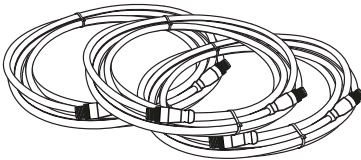
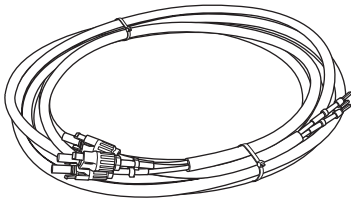

J1 Extension CAN BUS 6 m
J2 Extension CAN BUS 6 m
J5 Extension CAN BUS 6 m
stabilizer → driver

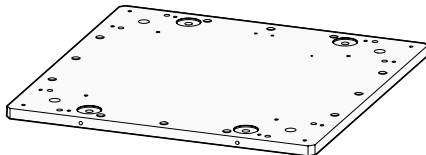

base plate (optional)

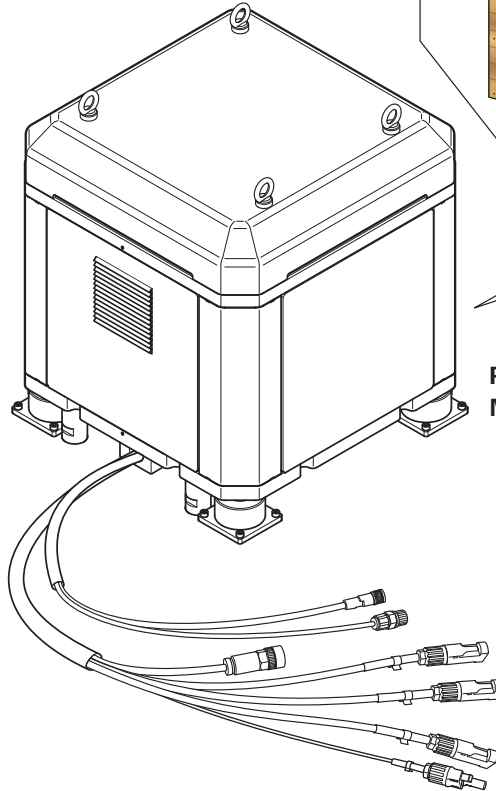

Prewired
MC²X7 stabilizer

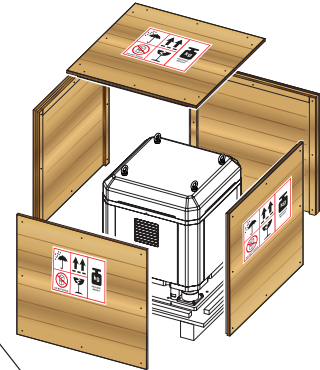

Screw



RC Remote Control MC²

Needed accessory and material included in its packaging
Not supplied with the stabilizer



J3 RC Extension cable
CAN BUS 12 m



Connector cable
CAN T 5P F/F/F



CAN
Terminator

RC REMOTE CONTROL MC²
touch - 5" - IP66
CAN BUS adapter cable (1 m / 3,28 ft)



2 - Supplied parts

MC² Quick gyro stabilizer is equipped with all the parts needed for its installation.

2.0 - Package contains the following parts

1 Pre-wired **MC²X7 Gyro stabilizer**

1 **Power cable** (6 m long)

1 **AC DYNAMIC CONTROL MC² Driver** to control and operate the gyro

1 **J1 Extention CAN BUS** (6 m long)

1 **J2 Extention CAN BUS** (6 m long)

1 **J5 Extention CAN BUS** (6 m long)

4 **Eye bolts** for **MC²X7** stabilizer lifting

1 **Template** to install the **MC²X7** stabilizer

8 **Screws** with resistance category higher than **10.9**. Tightening torque **130 Nm - M12**.

8 **Screws with base plate (optional)** with resistance category higher than **10.9**. Tightening torque **40 Nm - M8**.

1 **Template** to install the **AC DYNAMIC CONTROL MC² driver**

INSTALLATION AND USE MANUAL

The warranty

2.1 - Needed accessory and material included in its packaging Not supplied with the stabilizer

- **RC Remote Control MC² touch**, 5", IP66 - It allows you to turn the stabilizer on and off and monitor its status (also in multi-station).

Supplied with:

- template for mounting the Remote Control
- **J3 RC Extention CAN BUS** for the CAN BUS connection to the **RC Remote Control MC²**
- **CAN 5P T F/F/F connector**
- **CAN Terminator**.

2.2 - Required components, not supplied with the stabilizer

- Differential circuit breaker for connecting the AC DYNAMIC CONTROL driver.

2.3 - Tools needed for installation

- Lifting straps
- Torque wrench
- Drill & drill bit 11 mm (7/16")
- Fork key 17 mm (21/32")
- Hexagonal key 8 mm (5/16")



BEFORE PROCEEDING TO THE STABILIZER'S INSTALLATION, ALL THE PROCEDURES DESCRIBED AND ILLUSTRATED IN THIS INSTALLATION MANUAL MUST BE CAREFULLY READ AND CORRECTLY UNDERSTOOD.
IF IN DOUBT, IMMEDIATELY CONTACT YOUR NEAREST AUTHORISED QUICK® DEALER.

This document contains the instructions that are necessary for boat manufacturers and marine equipment installers to assemble and commission the **Quick® MC² gyro stabilizer**.

3.0 - General information

Quick stabilizers have been designed for fixed installations in a protected space.

Taking into account the wide range of hulls and types of boats, the installer shall be responsible for building a solid base that makes the stabilizer an integral part of the boat structure.

Nonetheless, Quick® is providing below some purely indicative illustrations that could be useful (See section 6.0).

The stabilizer's installation and following inspection and repair operations must be performed exclusively by qualified personnel.

The installer shall be responsible for the correct mechanical fixing, for the correct electrical connection, as well as for the effective stabilizer operation after its installation on the boat.

This device must not be used by people (including children) with reduced physical, sensory or mental abilities.

QUICK® SpA will not accept responsibility for direct or indirect damages caused by improper use of the equipment.

3.1 - Preliminary technical checks

Before proceeding to the installation, it is essential to make sure that the position chosen and the boat structure can withstand and enable the transfer of the loads generated by the gyroscope on the hull.

Load generated by MC²X7
 To calculate the structure sizing load use a safety factor (R = 3)

6678 N·m X 3 = 20034 N·m
 (1Kg = 9,81 N·m)

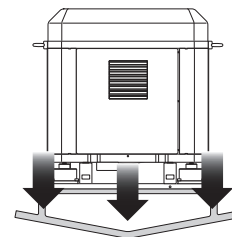

The supporting base must be properly dimensioned in order to withstand the declared stabilizing torque (Nm).

By sharing the total stabilizing torque on the three directions for each fixing screw (8 screws), the following torque will result on each dimension:

- **Fz: 12 kN**
- **Fx: 7,5 kN**
- **Fy: 1 kN**

The above-mentioned efforts must be considered to work simultaneously.

These efforts don't include voltages introduced by marine efforts during navigation.

If the installer do not able to guarantee that the boat structure is able to withstand and transfer the loads in the hull generated by the gyroscope, a qualified technician or a naval engineer should intervene in order to carry out a suitable structural analysis on site.

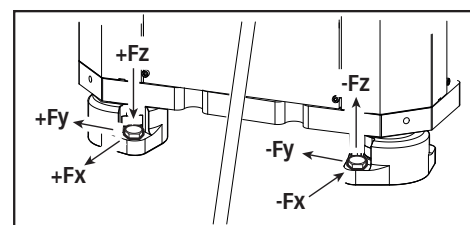
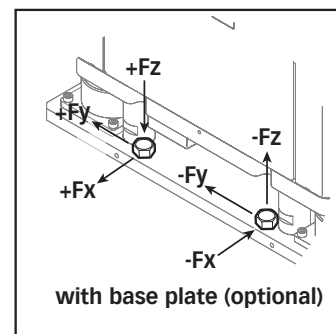



4.0 - Precautions

- Comply with all the safety warnings included in this manual.
- Comply with all the technical parameters indicated in this manual.
- The stabilizer must be lifted only by means of the lifting straps properly secured to the supports on the base of the product.
- Handle with care paying attention to avoid damaging the gyro or getting injured.
- Strictly observe all the local accident prevention standards during both assembling and regular operation.
- The work area shall be large enough to enable technicians to assemble/disassemble the stabilizer.
- The stabilizer must be installed in a suitably ventilated place.
- Maximum cleanliness must be guaranteed during operations.
- Do not place any objects on the anti-roll stabilizer
- The environment where the stabilizer is installed must be dry and clean (no water, no splashes)

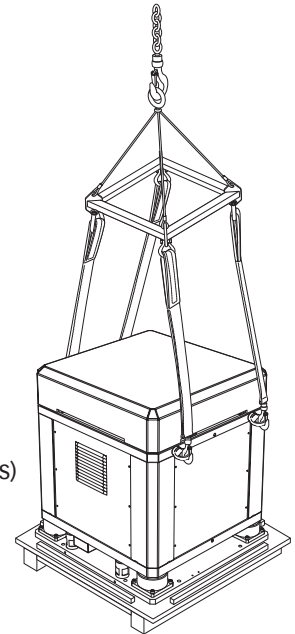

Further details on how to handle the appliance on section 5 of this manual.

4.1 - Warnings



- **The stabilizer operates within 90÷240 VAC power supply and LV version 90÷120 VAC. Connect to the electrical line in compliance with the protection standards in force. The stabilizer motor frame must be properly grounded in order to guarantee the necessary protection in case of indirect contact.**
- **While navigating, if the stabilizer rotates at its maximum speed, NOT to disconnect the power supply, in order to avoid interrupting the gyroscope precession motion control.**
- Secure the stabilizer to the boat structure by means of **screws/nuts with strength class no less than 10.9.**
- For tightening, use a torque wrench with the torque indicated by the manufacturer (see section 7.4 and 7.5)



DUE TO THE EXTREMELY HIGH ROTATION SPEED OF STABILIZERS, INSTALLERS AND USERS MUST STRICTLY COMPLY WITH THE FOLLOWING WARNINGS:

- Activate the stabilizer only after having installed it correctly.
- Activate the stabilizer with the protection devices inserted
- Do NOT touch the stabilizer while it is running to prevent the danger of getting seriously injured and damaging the gyroscope.
- Do NOT remove the external cover.
- Do NOT place any object, hands or body near the rotation area.
- Do NOT introduce extraneous objects inside the protection cover.



*** Disconnect the stabilizer from the power supply and make sure that the flywheel has stopped completely before performing any operation (see info on display RC), such as cleaning or a simple inspection,** in order to prevent any damage to people or objects caused by an accidental start-up.

*** Restore the power supply only after having correctly installed all the safety devices that were removed to carry out the operations.**



*** Do NOT perform any type of electrical maintenance on any system device while the stabilizer is disconnected from the power supply and the FLYWHEEL IS STILL ROTATING, as its force continues to generate current.**



* CLEANING THE APPLIANCE





- Do NOT use solvents or fuels to clean the appliance.
- Do NOT remove the safety labels on the equipment.

*** WARNING: THIS OPERATION MUST BE CARRIED OUT BY QUICK AUTHORIZED PERSONNEL ONLY. REMOVING THE COVERS AND SEALS WILL VOID THE QUICK WARRANTY.**





4.2 - Personal protection equipment (PPE)

The personal protective equipment must comply with the national standards pertinent and must be checked, kept efficient and used according to the manufacturer’s instructions.

PPE for the worker assigned to the installation and ordinary maintenance		
Identification pictogram	Description	Notes
	HELMET	Protective helmet to prevent injuries caused by overhanging loads and knocks against structures.
	GLOVES	Use of protective gloves to avoid cuts, punctures or pricks during operation.
	SHOES	Use of safety footwear to avoid damages caused by materials falling from a height during stabilizer installation operations.
	CLOTHES	Use of suitable protective clothing to avoid it getting caught in moving or transported parts.
	EYEGASSES	Protect your eyes with eyeglasses or protecting screens in case of operations near the hydraulic system in pressure.

4.3 - Stickers/labels on the stabilizer

On the stabilizer will be applied stickers/labels that report dangers and attention to be taken for the correct use.

Label pictogram	Description	Notes
	DANGER	DANGER OF CRUSHING HANDS AND FEET
	DANGER	RISK OF ROLLOVERING CRUSHING
	CAUTION	MOVING AND ROTATING EQUIPMENT





4 - Safety

4.4 - Cases

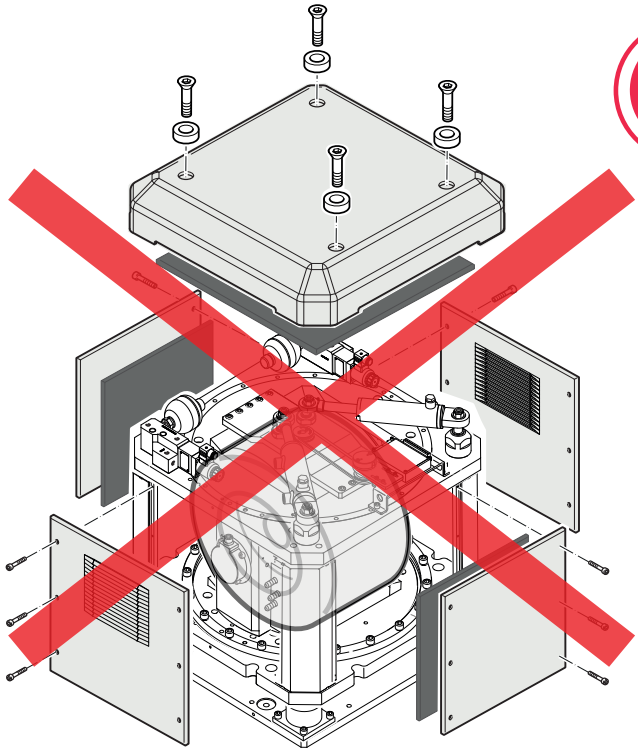
 **FOR NO REASON REMOVE THE PROTECTION CASES**



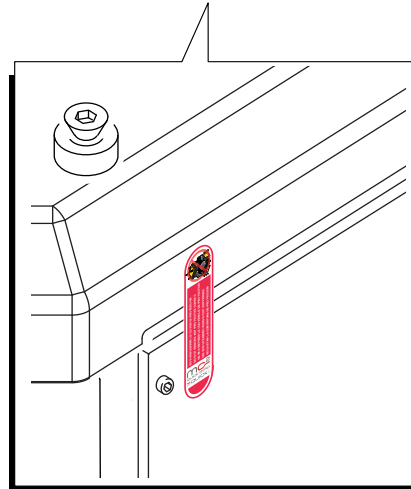

NON RIMUOVERE LE COVER DI PROTEZIONE
DO NOT REMOVE ANY PROTECTIVE COVERS
NE PAS RETIRER LES COUVERCLES DE PROTECTION
DIE SCHUTZABDECKUNG NICHT ENTFERNEN
NO QUITAR LAS TAPAS DE PROTECCIÓN

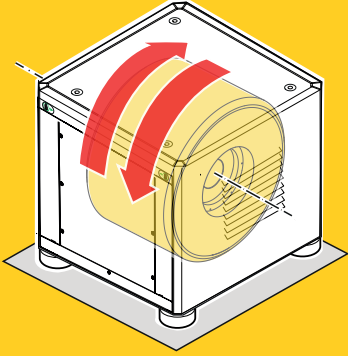

4.5 - FLYWHEEL ROTATION



	FLYWHEEL ROTATION: Hourly or counterclockwise bound to the verse of stabilizer assembly
	The direction of rotation of the flywheel is indicated by the label on stabilizer cover

DIRECTION OF ROTATION



PAL.MC2DR000

4.6 - Air output

The label will indicate the stabilizer air outlet area during operation.





5.0 - General instructions and precautions

The weight to be considered for lifting the **MC²X7** stabilizer is **300 kg (661,4 lb)**

The stabilizer must be handled and transported by qualified personnel that can anchor the loads in compliance with local safety regulations in the workplace.

- The stabilizer must be lifted by means of a suitable hoist, using the lifting straps properly secured to the supports on the base.
- While removing the stabilizer from its packaging or while lifting it, it is necessary to work with caution, paying attention to NOT cause damage to the equipment or allow it to hit the ground. Before installation on board, we recommend resting the unit on a shockproof surface (e.g. wood, cardboard, cloth)
- Prevent electrical components from coming in contact with any surface or object, as this could damage such components.
- Do not scratch or cut on the painted finish that protects the stabilizer.

5.1 - Crate Removal

1. Remove the top cover of the crate.
2. Remove the side panels of the crate.

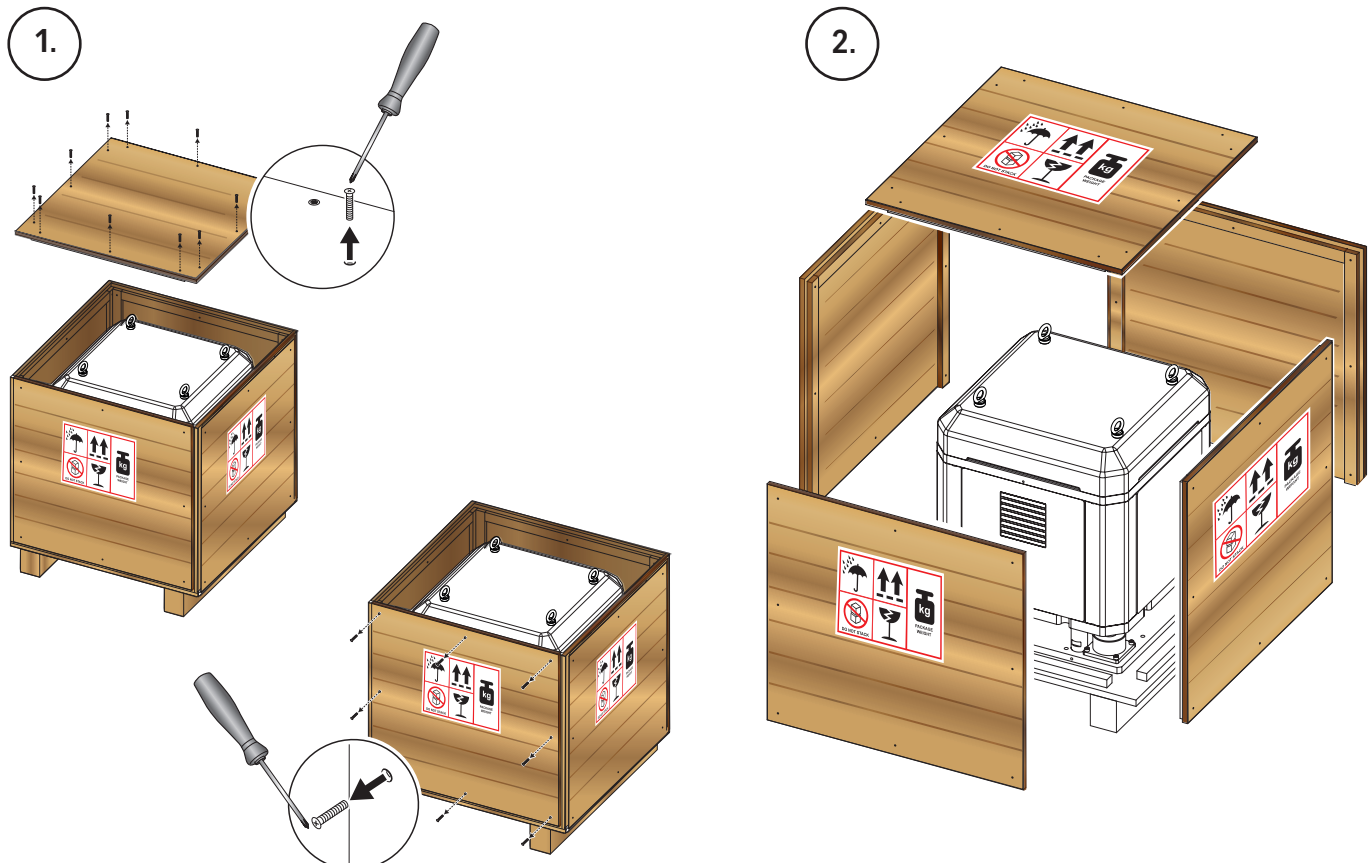



5.2 - Lifting the stabilizer

3. Lift the stabilizer with the straps properly secured to the supports on the base. Use spacers for ropes to prevent damaging cables or connectors.
4. Lift the stabilizer, and remove the screws from the wood base on which the stabilizer is fixed.



NEVER LIFT THE STABILIZER INTO THE CONDITION IN EXAMPLE 5.

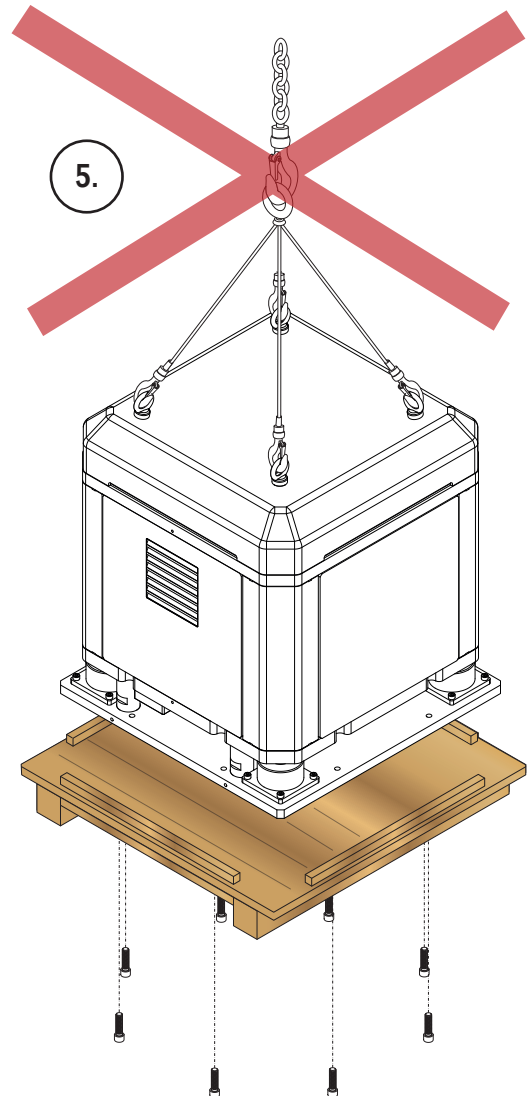
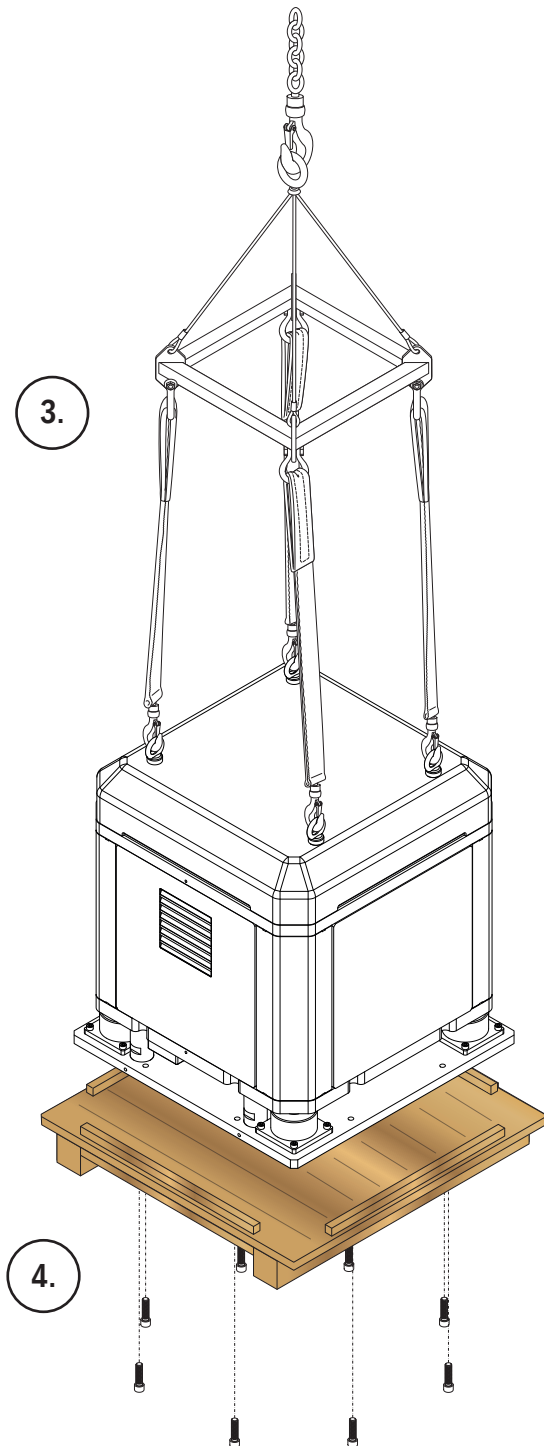



The selection of the area and the position on the boat requires taking some aspects in consideration, which will be illustrated in the sections below by means of rules and recommendations.

6.0 - Structure and housing analysis

Before any assessment on the ideal location, it is necessary to make sure that the position chosen and the boat structure are suitable to withstand and transfer to the hull the loads generated by the gyroscope on the hull.

If the installer does not have the necessary skills to perform this type of check, a qualified technician or a naval engineer should be consulted to conduct a structural analysis on site.

6.1 - Environmental requirements

- We recommend positioning the stabilizer in a dry, ventilated place in order to enable it to operate at full power and be protected from atmospheric agents.
- Like for other machinery, for greater comfort we recommend choosing an engine compartment already fitted with acoustic insulating material. The noise generated by MC²X7 is < 70 dB (measured in stable conditions, without wave motion).

- The work area shall be large enough to enable technicians to assemble/disassemble the stabilizer as well as having access to it to maintenance.

To determine whether there is enough free space around the stabilizer, it is also necessary to make sure that there is enough space to remove the external cover, to be able to access the connections, and to not obstruct other equipment nearby

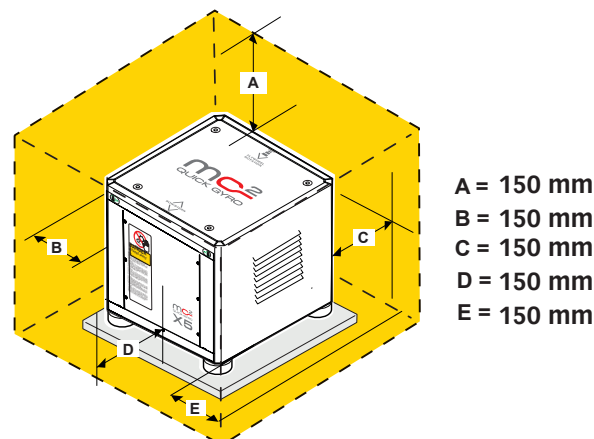

Upon request, 2D and 3D dimensional drawings can be provided to accurately assess the dimensions

6.2 - Water line

The installation of the stabilizer must be carried out with the value of the inclination of the plane of the hull of ± 2 degrees with respect to the water line.

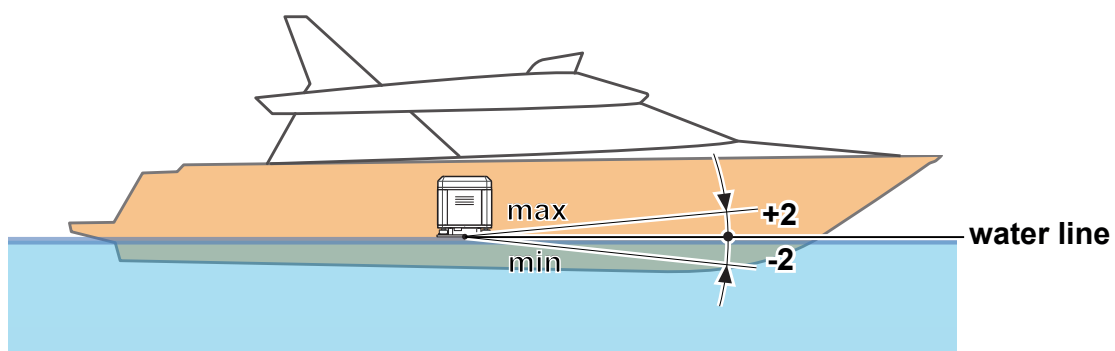



6.3 - Installing a single stabilizer

The installation of a single stabilizer can be done in any area of the boat, taking into account the following necessary indications for the correct operation of the appliance:

- We recommend installing the stabilizer in the **lower area of the hull**, taking into account the available space and the environmental requirements described in **section 6.1**.
- **IMPORTANT: POSITION THE STABILIZER FOLLOWING THE INDICATIONS OF THE DRILLING TEMPLATE.**
- **THE STICKER ON THE COVER (FLYWHEEL ROTATION) MUST BE POSITIONED TOWARDS THE STERN OR TOWARDS THE BOW.**

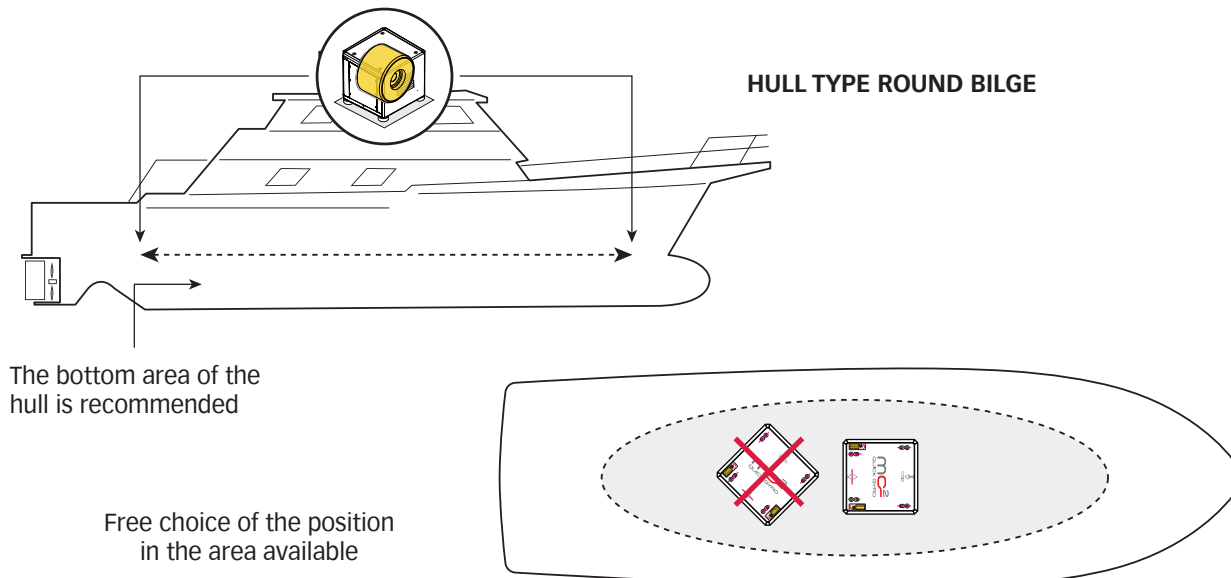
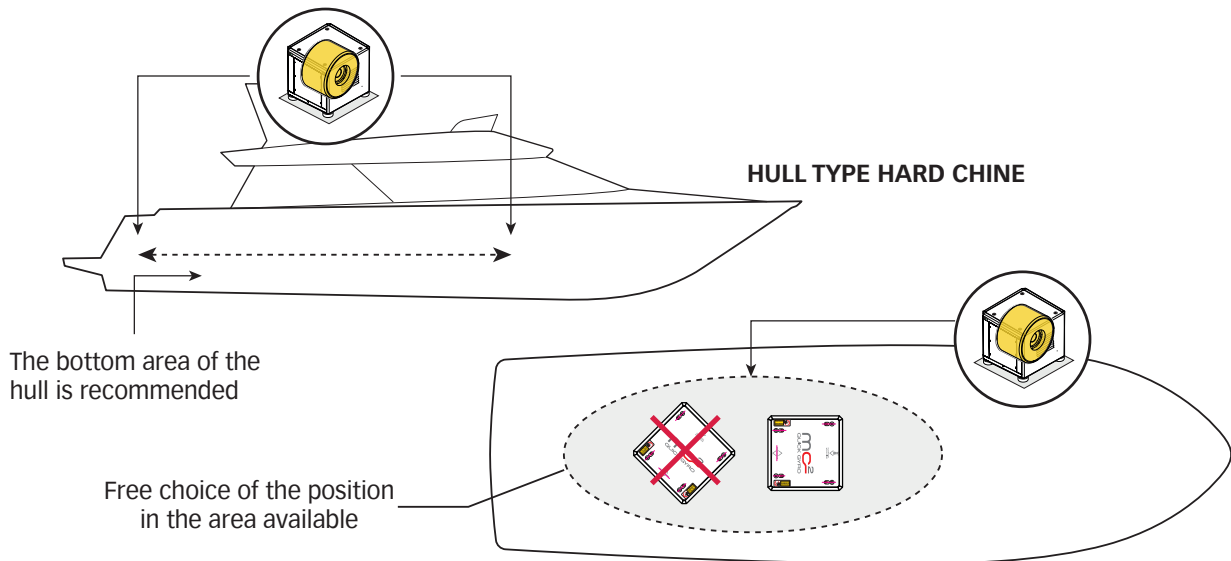
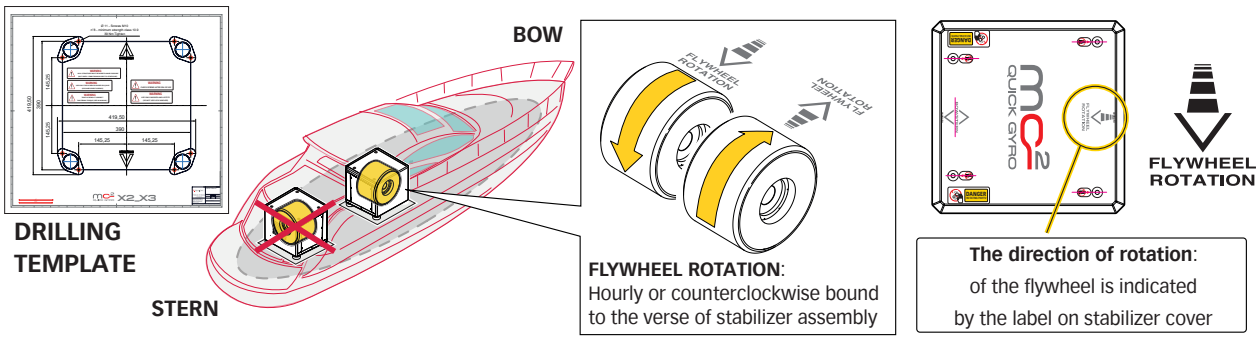



6.4 - Installation of multiple units on the same boat

The installation of multiple stabilizers on the same boat can be done taking into account the following necessary requirements for correct operation:

- We recommend installing the stabilizers in the **lower area of the hull**, taking into account the available space and the environmental requirements described in **section 6.1**.
- **IMPORTANT: POSITION THE STABILIZER FOLLOWING THE INDICATIONS OF THE DRILLING TEMPLATE.**
THE STICKER ON THE COVER (FLYWHEEL ROTATION) MUST BE POSITIONED TOWARDS THE STERN OR TOWARDS THE BOW.
- For the installation of several units, position the stabilizers so that the rotations of the flywheels are opposite.

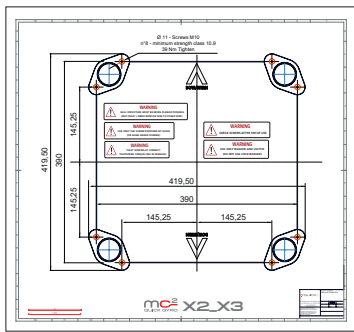

DRILLING TEMPLATE

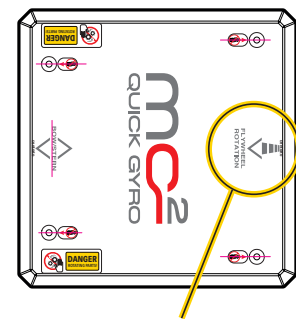
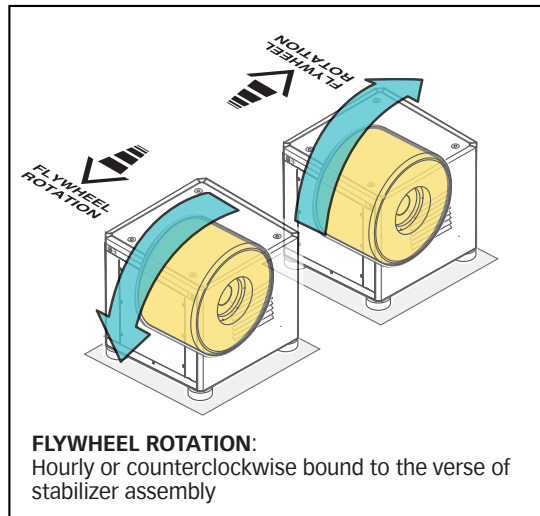

 **The direction of rotation:**
of the flywheel is indicated by the label on stabilizer cover

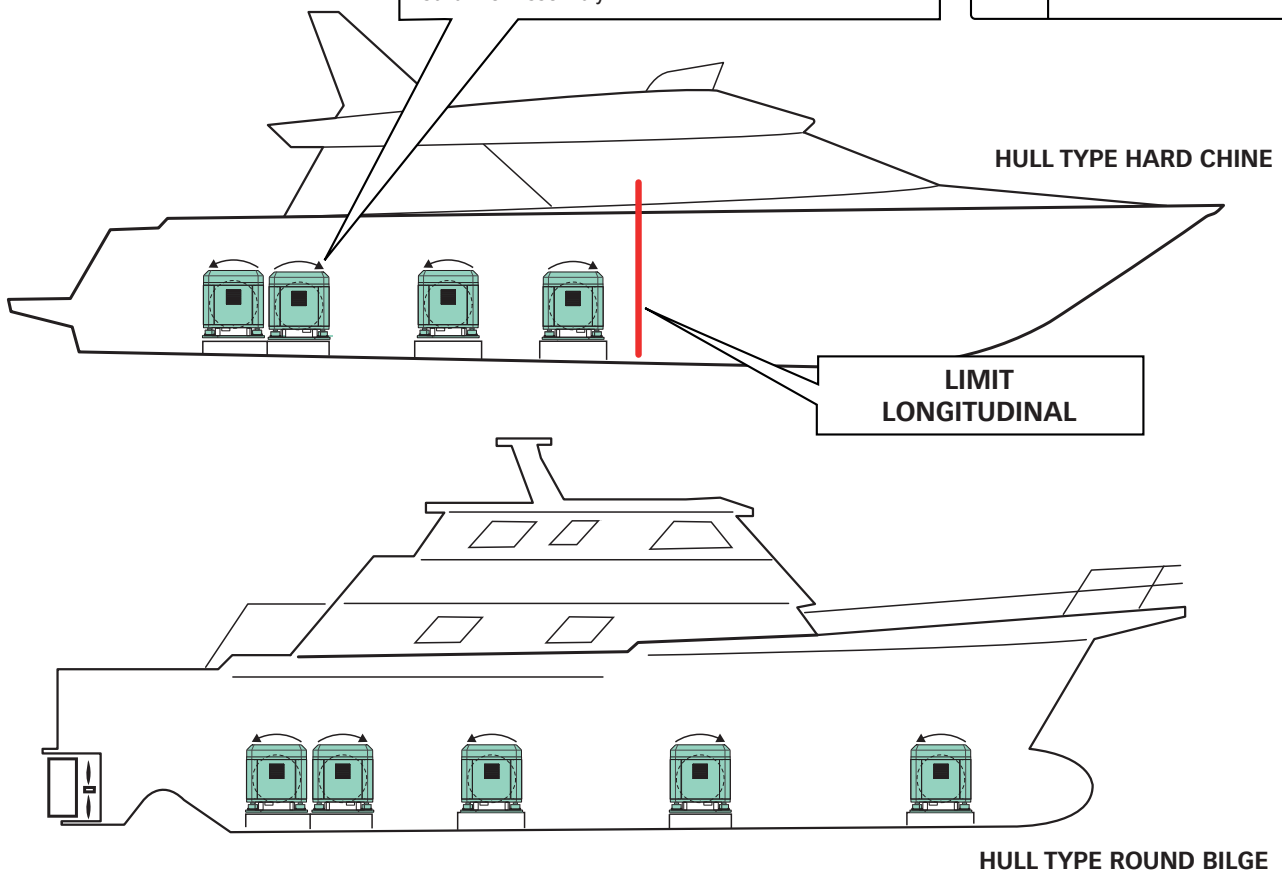



The installation instructions include all the procedures that are necessary to assemble and fix the stabilizer. Quick® provides all the mechanical and electrical components for the correct operation of the appliance.

7.0 - Support structure

The reinforced mounting structure that supports the stabilizer must be designed and built according to the boat characteristics and should be made by a certified installer or a boatyard.

The mounting structure should be built by qualified personnel only after having conducted a suitable analysis on the loads that the gyroscope will transfer to the hull (see section 6.0).

Quick® SpA will assume no responsibility for the manufacturing of the mounting structure on which the stabilizer is to be installed.

However, considering a typical installation, it is advisable to refer to the examples that will follow in points 7.4 and 7.5 of this manual. These examples are to be considered purely indicative.

7.1 - Types of Underbody

• Fiberglass hulls

The fiberglass support shall be laminated to the hull, in compliance with the regulations in force.

Considering the mechanical stress to which the hull will be subjected, extra care should be placed on the lamination. If the support structure has to be reinforced, we recommend incorporating aluminum or brass plates in the fiberglass.

• Aluminum alloy or steel hulls

The aluminum alloy or steel mounting structure shall be welded to the hull. Consult the manufacturer/boatyard, naval engineers and/or specialized companies to assess additional modifications such as cross-beams and stringers near the unit to be installed.

• Wood hull

Consult the manufacturer/boatyard, naval engineers and/or specialized companies to assess suitable additional modifications.

7.2 - Warnings



Prevent dust or any type of fragment from accidentally getting inside the gyroscope. Keep the equipment protected and clean and clean the base very thoroughly before installing it, especially after the preparation and drilling phases.

• The stabilizer must be installed parallel to the boat's transverse axis.

• **IMPORTANT: POSITION THE STABILIZER FOLLOWING THE INDICATIONS OF THE DRILLING TEMPLATE.**

THE STICKER ON THE COVER (FLYWHEEL ROTATION) MUST BE POSITIONED TOWARDS THE STERN OR TOWARDS THE BOW.

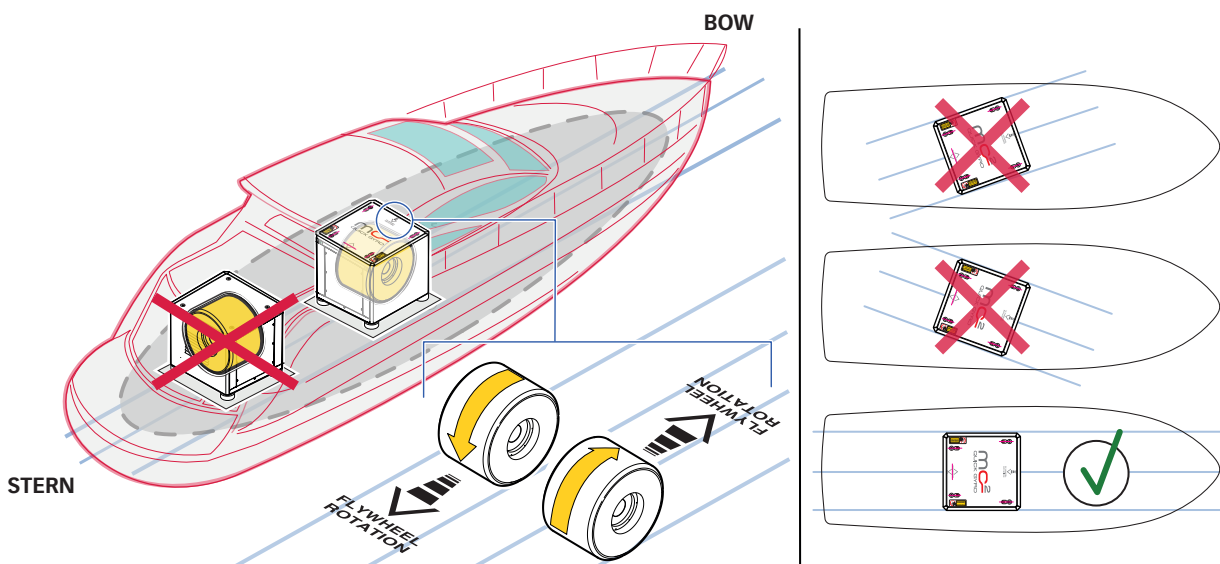

7.3 - Planarity of installation

In the two configurations with base plate (optional) and without base plate, the stabilizer installation must respect the planarity with the relative tolerance values.

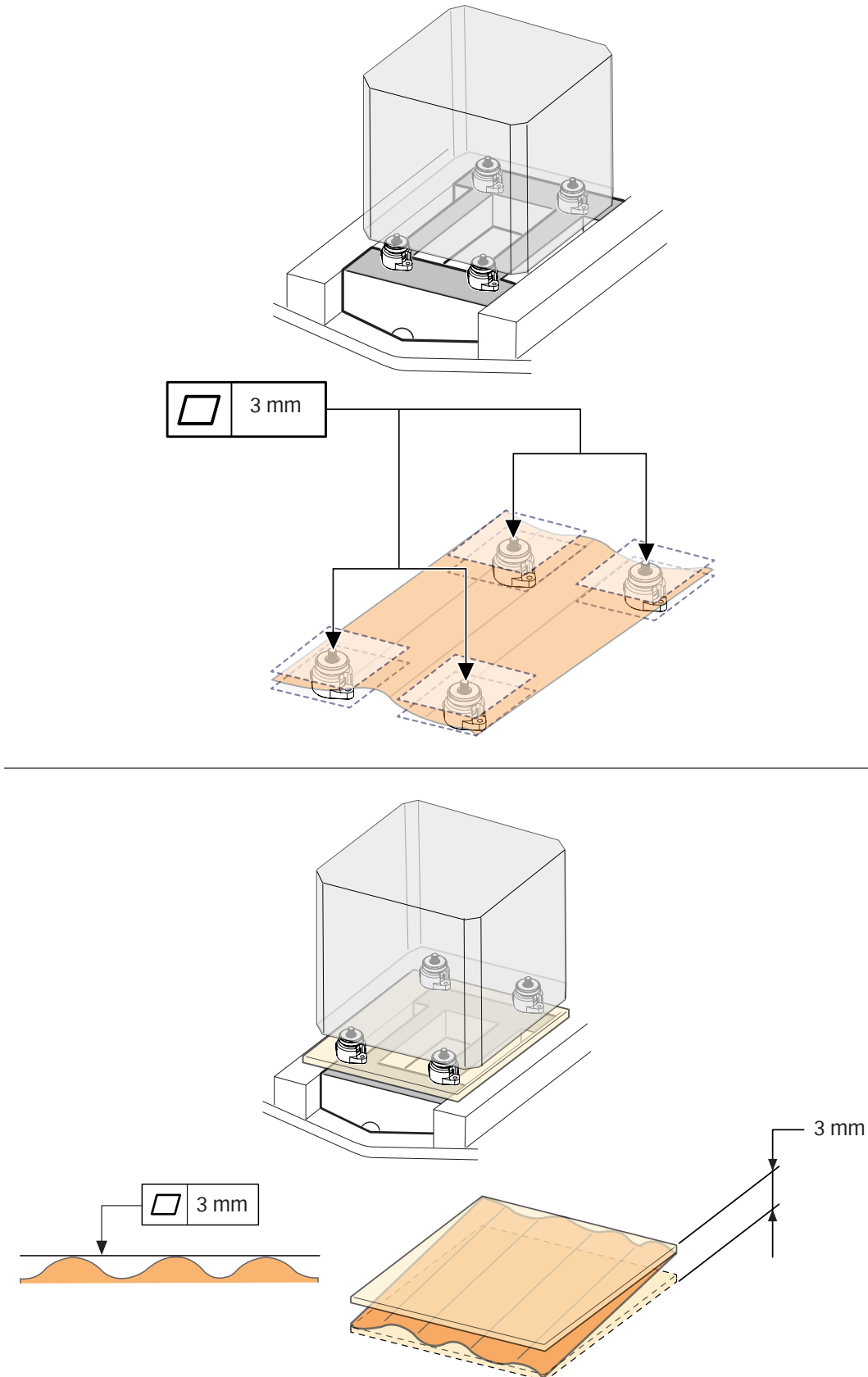

7.4 - Securing

In the condition where there is enough space to access the silent blocks, the stabilizer will be positioned using the drilling template and fixed with the relative screws.

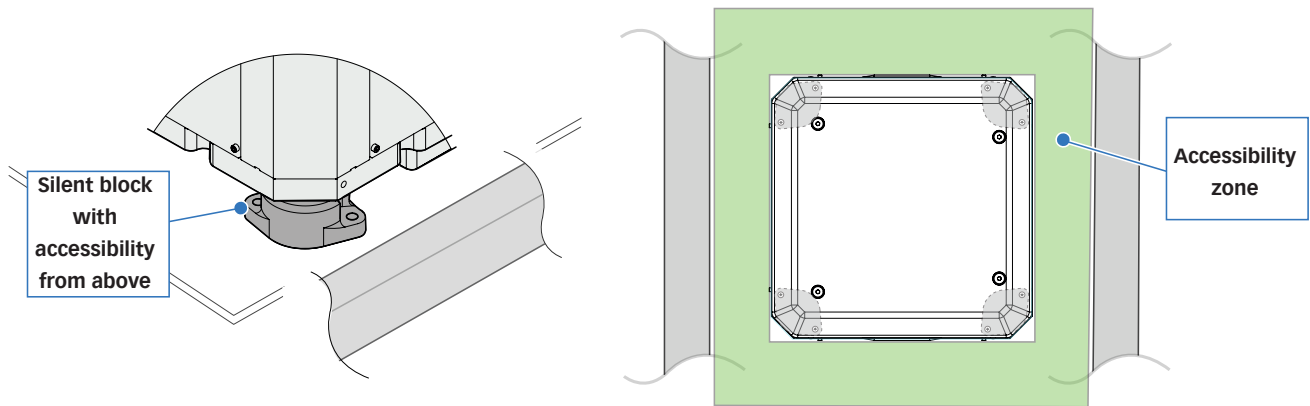

Use the drilling template supplied to mark the anchoring points before positioning the gyroscope.

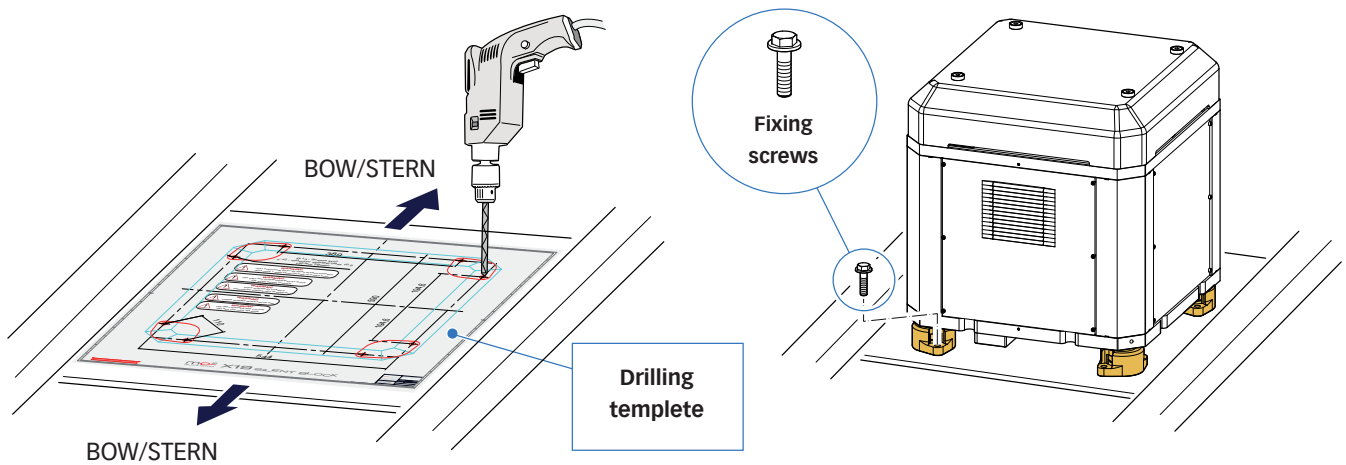

• Quick® MC²X7 shall be secured by means of screws with strength class no less than **10.9**, Tightening torque **130 Nm - M12** (the screws are supplied with the product).

- For tightening, use a **power drill** to tighten the Phillips head screws.
- Tighten gradually in a criss-cross pattern.
- Use suitable locking systems.



WARNING: Approximately one week after installation, check screws/nuts for proper tightening. Periodically check the tightening of the screws for potential settling adjustments.



7.5 - Stabilizer securing with base plate (optional)

In the condition where the screws of the silent blocks ARE NOT accessible, to fix the stabilizer must be the relative base plate available as OSP (original spare part).

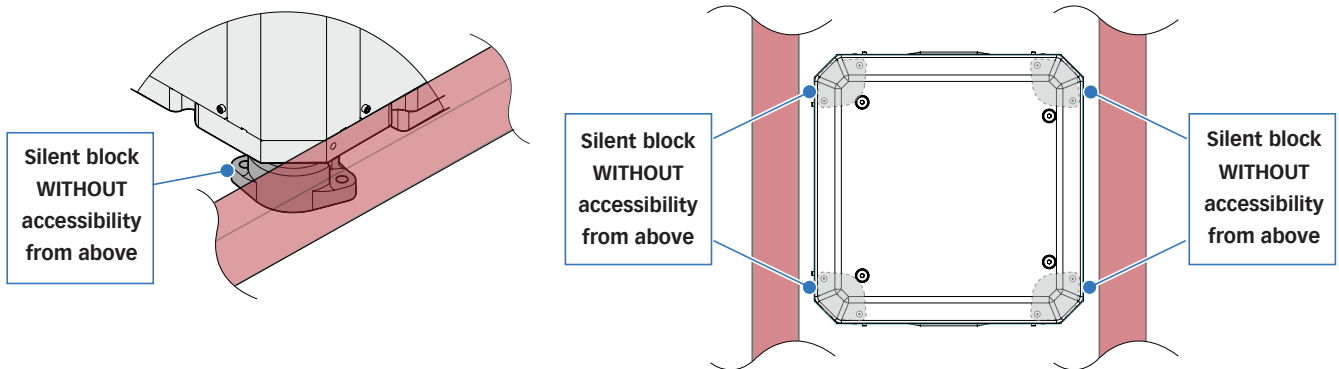

Fix the stabilizer on the base plate

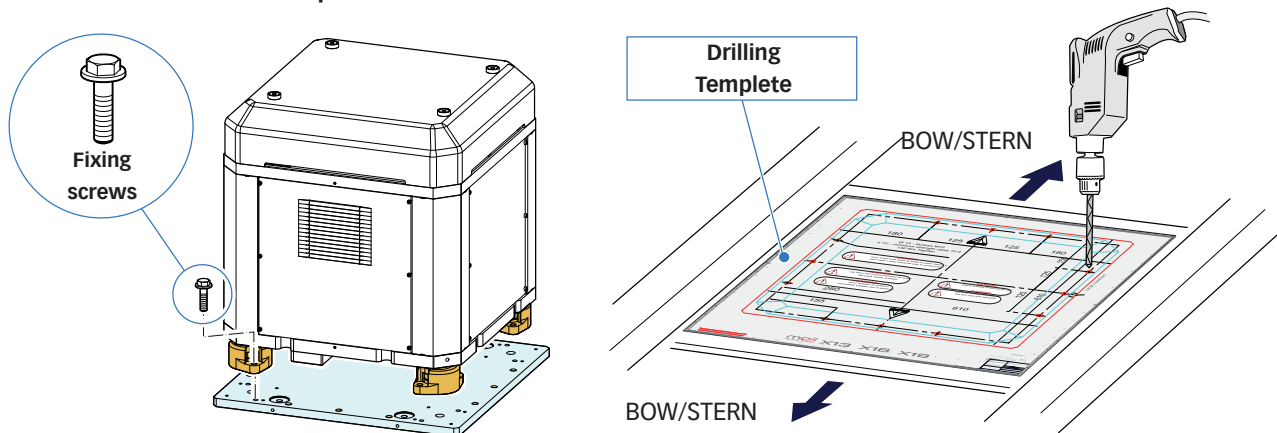

Use the drilling template supplied to mark the anchoring points before positioning the gyroscope.

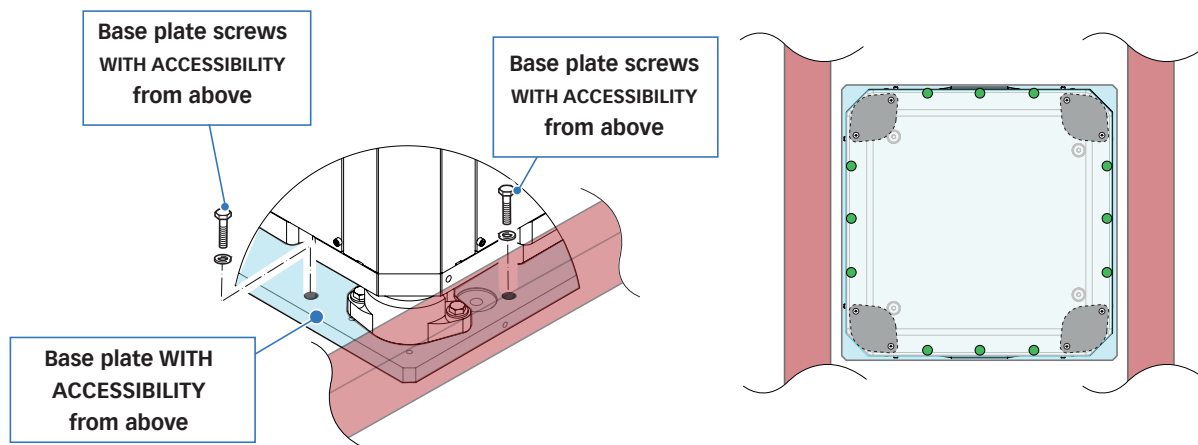

- Quick® MC²X7 shall be secured by means of screws with strength class no less than **10.9**, Tightening torque **40 Nm (345.179 lbf/inch) - M8*45** (the screws are supplied with the product).
- For tightening, use a **power drill** to tighten the Phillips head screws.
- Tighten gradually in a criss-cross pattern.
- Use suitable locking systems.



WARNING: Approximately one week after installation, check screws/nuts for proper tightening. Periodically check the tightening of the screws for potential settling adjustments.



THE EXAMPLES (1,2,3 and 4) THAT FOLLOW ARE ONLY FOR INDICATIVE PURPOSE



DO NOT USE
GROWER
WASHERS
FOR FIXING TO
ANY
STRUCTURES
AND / OR
FASTENINGS
ON THE BOAT

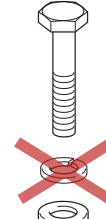
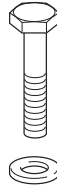

NO GROWER WASHER

7.4 - Fiberglass Support - Example 1

1 - Example of fiberglass support structure with brass plates on a hull with enough space in between the stringers.

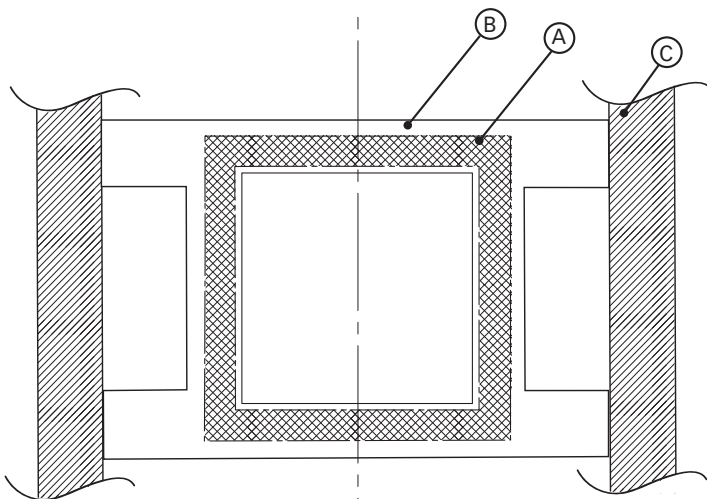

- A SADDLE
- B BRASS PLATE
- C EXISTING STRINGERS
- D FIBERGLASS
- E FILLING

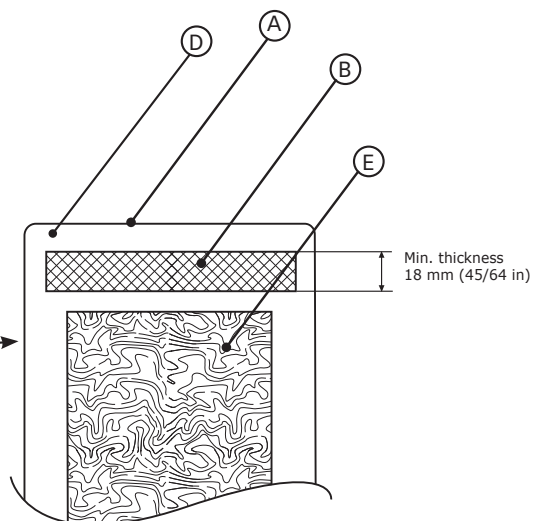
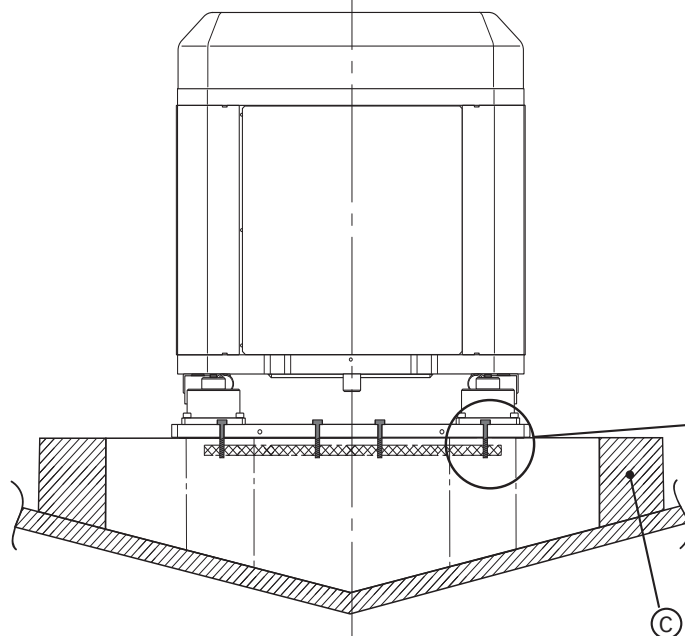
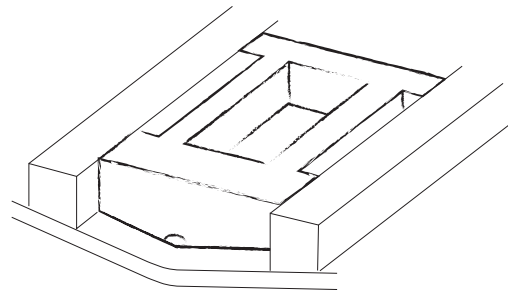

7.5 - Fiberglass Support - Example 2

2 - Example of fiberglass support with brass plates on hull with insufficient space in between the longitudinal stringers.

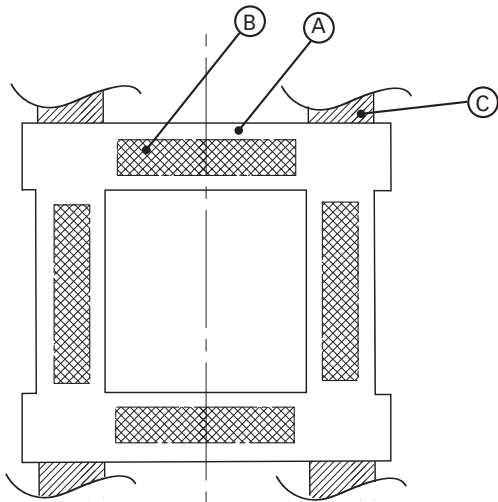

- A SADDLE
- B BRASS PLATE
- C EXISTING STRINGER
- D FIBERGLASS

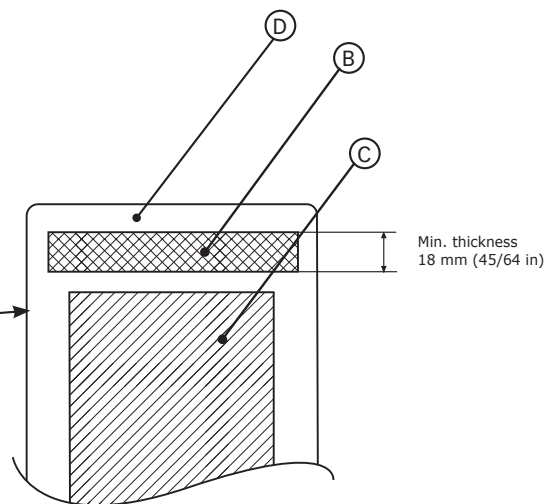
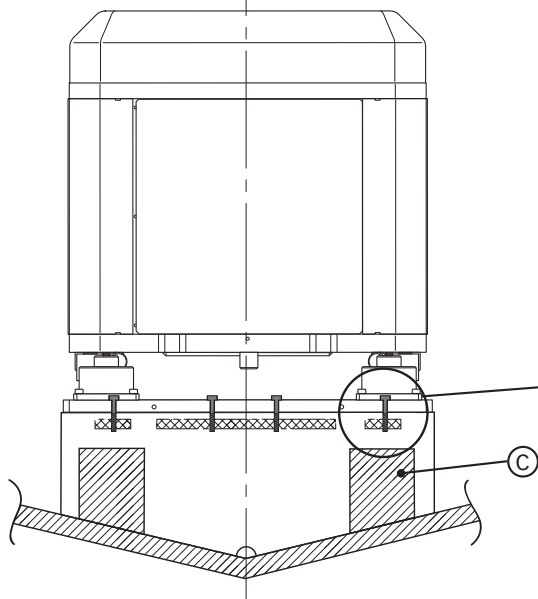
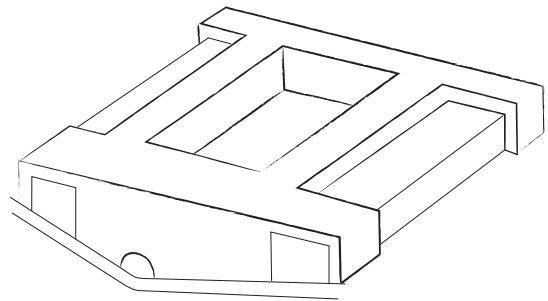



7.6 - BRACHET - EXAMPLE 3

3 - Example of support structure on a hull with enough space in between the stringers.

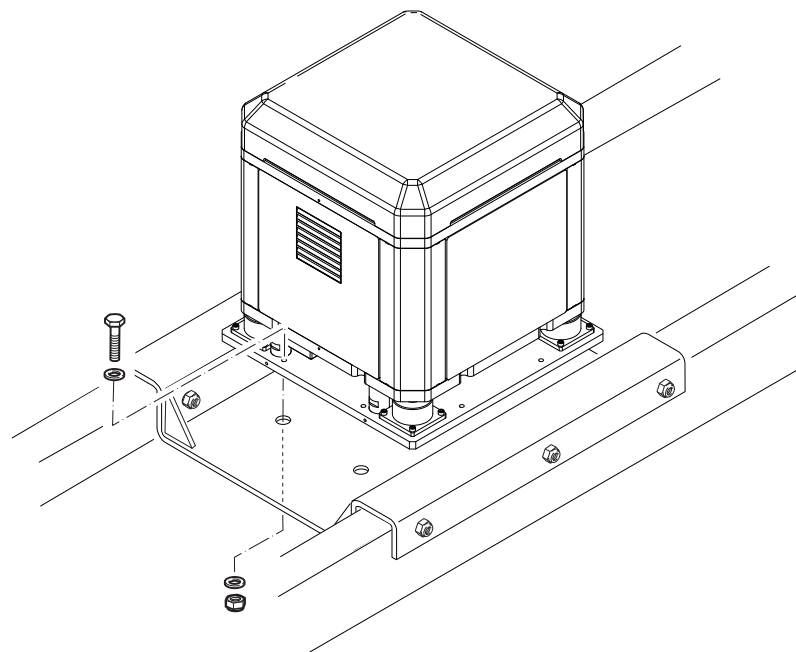
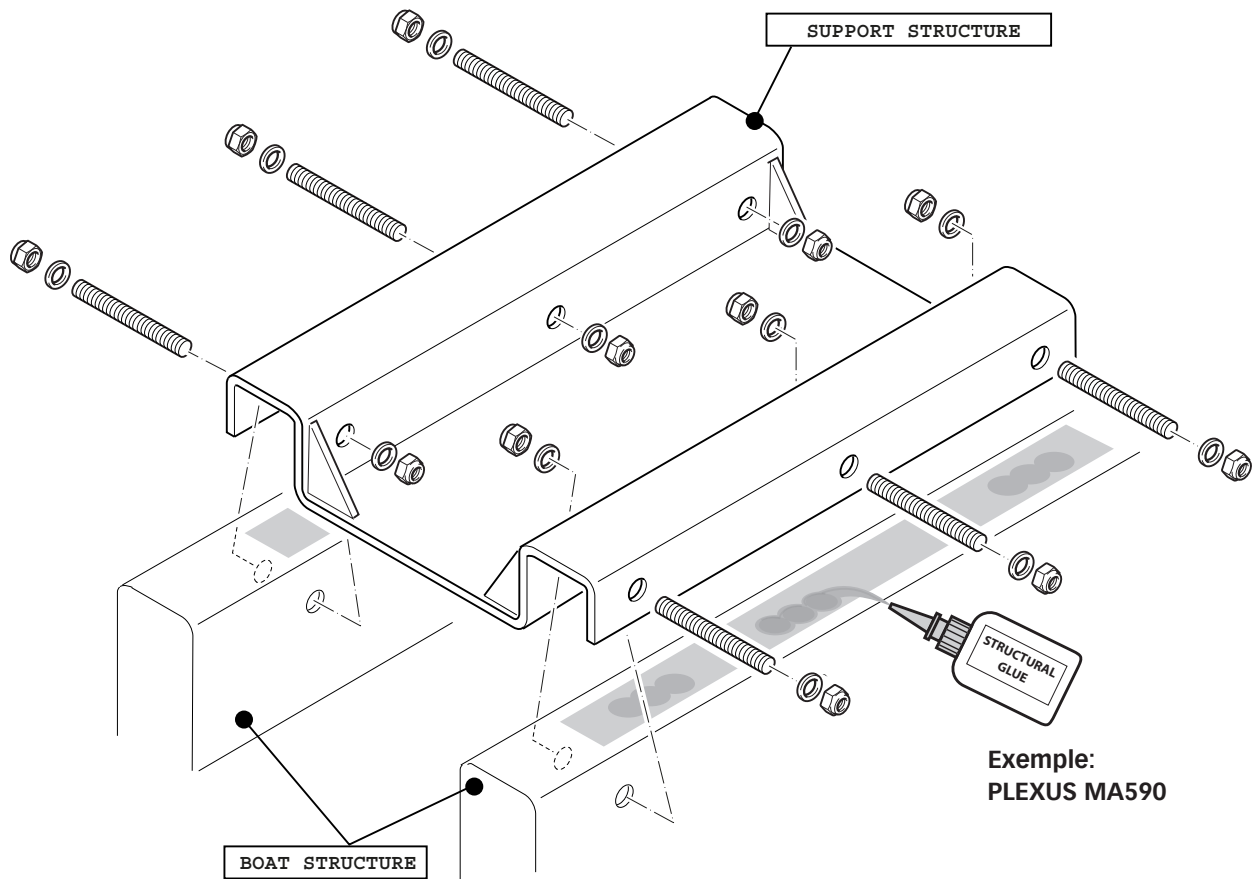

7.7 - BRACHET - EXAMPLE 4

2 - Example of support structure on a hull with insufficient space in between the longitudinal stringers.

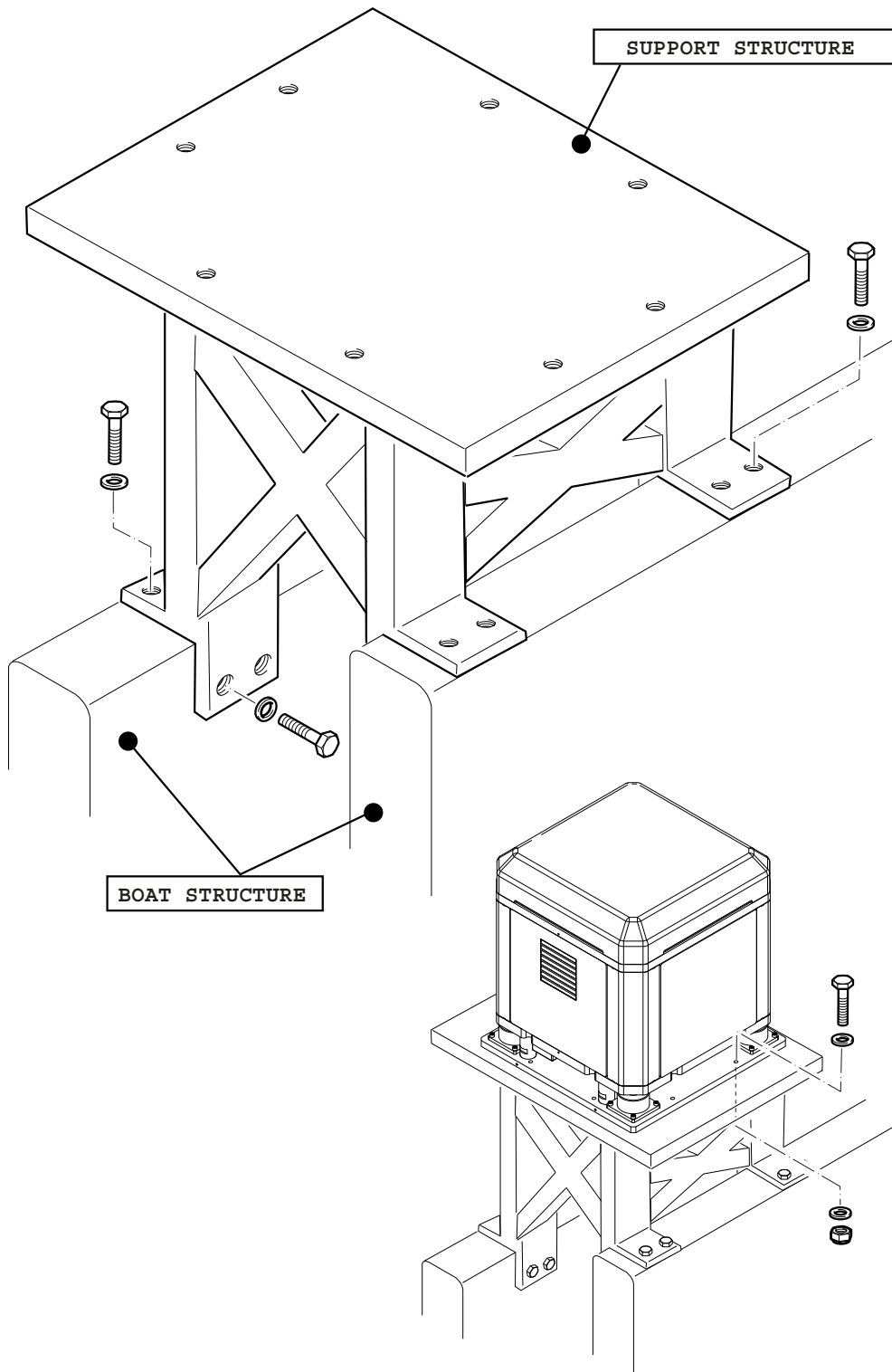



8 - Electrical connection

mc²
QUICK GYRO X7

EN

The stabilizer is supplied already pre-wired; each connector has a tag with instructions aimed at facilitating electrical connections.



DO NOT MODIFY THE OUTPUT POSITION OF THE STABILIZER'S PREWIRED CABLES.



MAKE SURE TO CONNECT THE DRIVER AND THE STABILIZER WITH THE SAME SERIAL NUMBER.

Operation range: 90-240 Vac (single-phase) - Frequency 50/60 Hz.

LV version - Operation range: 90-120 Vac (single-phase) - Frequency 50/60 Hz.

8.0 - Connection system devices

AC DYNAMIC CONTROL MC² - DRIVER

Gyroscope control and management unit.

Install the AC DYNAMIC CONTROL MC² driver in a dry, ventilated place in order to enable the stabilizer's operation at full power.

The driver is supplied with a drill template.



THE DRIVER MUST BE INSTALLED AT A SUITABLE DISTANCE FROM THE STABILIZER TO ENSURE THAT, DURING FULL-SPEED OPERATION, THE HOT AIR FLOW COMING FROM THE STABILIZER DOESN'T JEOPARDISE THE DRIVER'S FUNCTIONING.

- The driver must be installed with the wire connections at the bottom.
- It is recommended to install this device in a vertical position in order to facilitate its cooling.
- Fix to the support surface with suitable screws that can support its weight without causing structural damage to the boat.
- The driver (excluding the side to be fixed) must be placed at least 5 cm. (2 in.) away from walls or objects.

Wiring must be performed following the instructions outlined in section 8.2

RC REMOTE CONTROL MC²

The **RC Remote Control MC² touch** is the dashboard device that is used the stabilizer monitoring.

The panel features an LCD display to access the controls to turn the stabilizer on/off, and to display its status and correct operation (multi-station compatible).

Connection by means of a DB connection cable (CAN-BUS).

RC MC² is supplied a drill template. Available in sizes 5" graphic display. IP66.

* Not supplied



8 - Electrical connection

8.1 - Devices dimensions

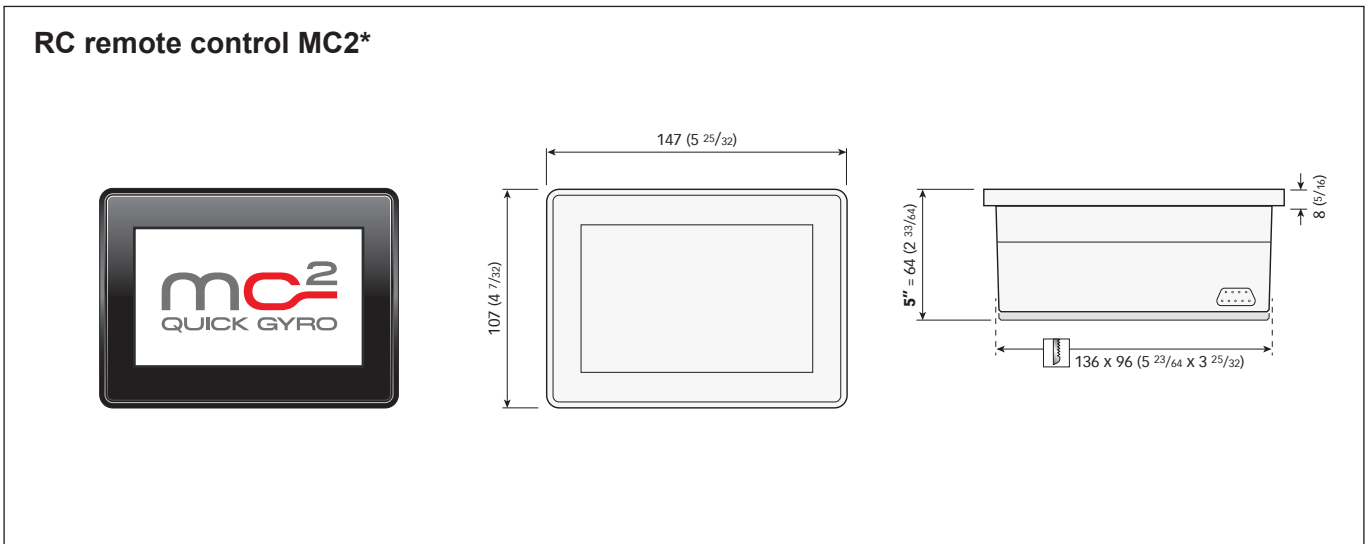
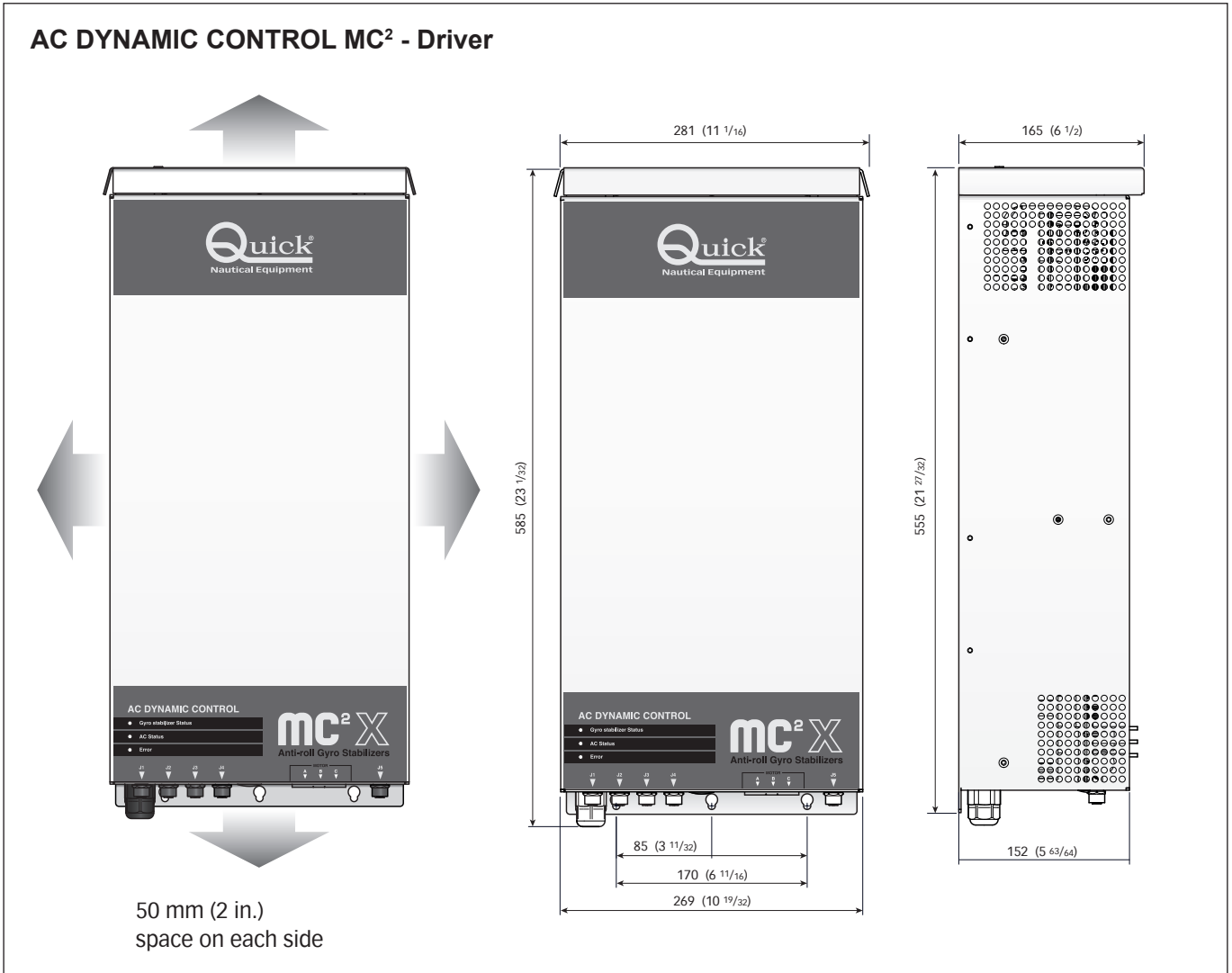

* Not supplied.

Dimensions in mm (inch)

8.2 - Connection diagram

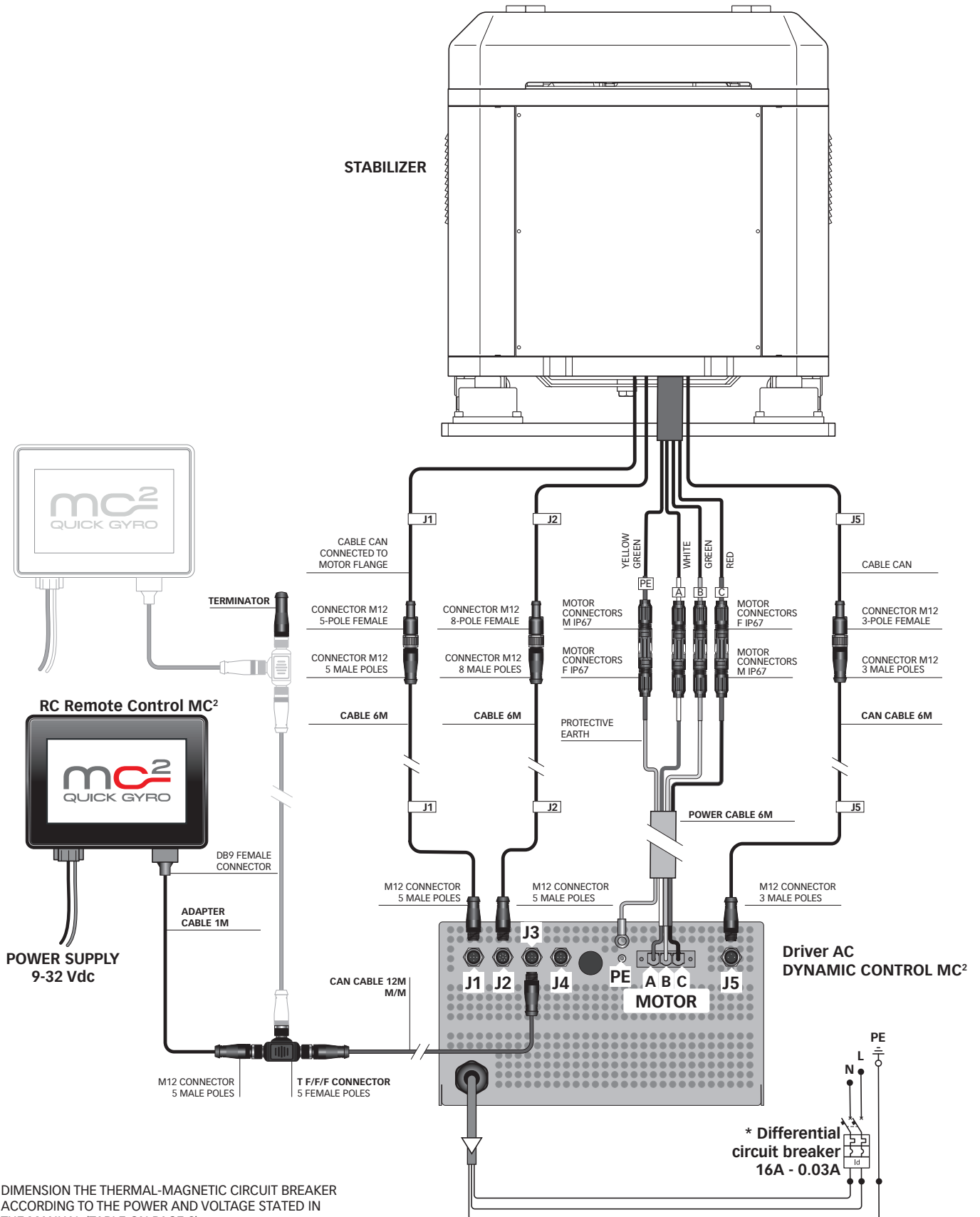

* DIMENSION THE THERMAL-MAGNETIC CIRCUIT BREAKER ACCORDING TO THE POWER AND VOLTAGE STATED IN THE MANUAL (TABLE ON PAGE 8).

8.3 - Driver and stabilizer connection

⚠ CONNECT DRIVER AND STABILIZER WITH SAME SERIAL NUMBER.

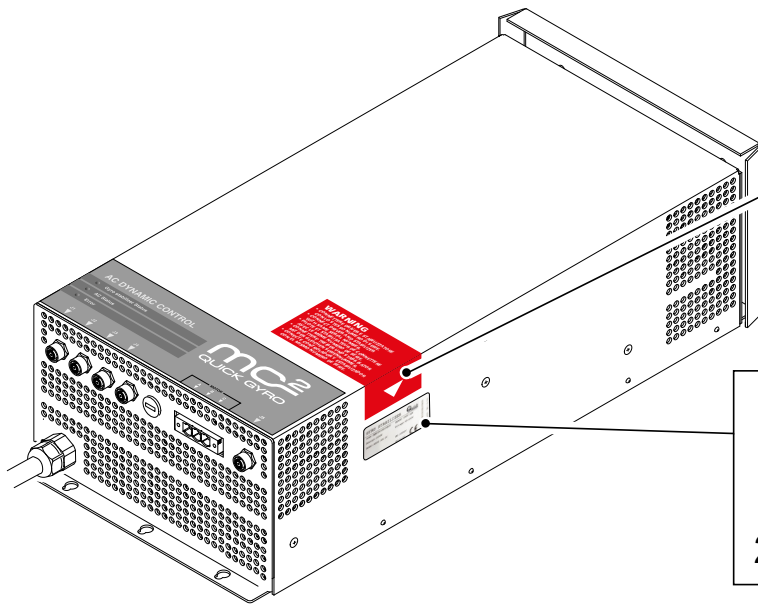

1

WARNING

- CONNETTERE DRIVER E STABILIZZATORE CON LO STESSO NUMERO DI SERIE.
- CONNECT DRIVER AND STABILIZER WITH SAME SERIAL NUMBER.
- PILOTE ET STABILISATEUR DE CONNETTERE AVEC LE MEME NUMERO DE SERIE.
- CONNETTERE-TREIBER UND STABILISATOR MIT DER GLEICHEN SERIENNUMMER.
- CONECTE CONTROLADOR Y ESTABILIZADOR CON EL MISMO NÚMERO DE SERIE.

2

GYRO STABILIZER	
Code: FQMC2X16KLV0A00	Speed: 5000 rpm
Absorpt: 2200W	Voltage: 90-260V
Model: MC2X 16k LV	
SN: 100027	CE
WY: 11/19	

Code: FQMC2X16KLV0A00
SN: 100027 WY: 11/19

2

GYRO STABILIZER	
Code: FQMC2X16KLV0A00	Speed: 5000 rpm
Absorpt: 2200W	Voltage: 90-260V
Model: MC2X 16k LV	
SN: 100027	CE
WY: 11/19	

Code: FQMC2X16KLV0A00
SN: 100027 WY: 11/19

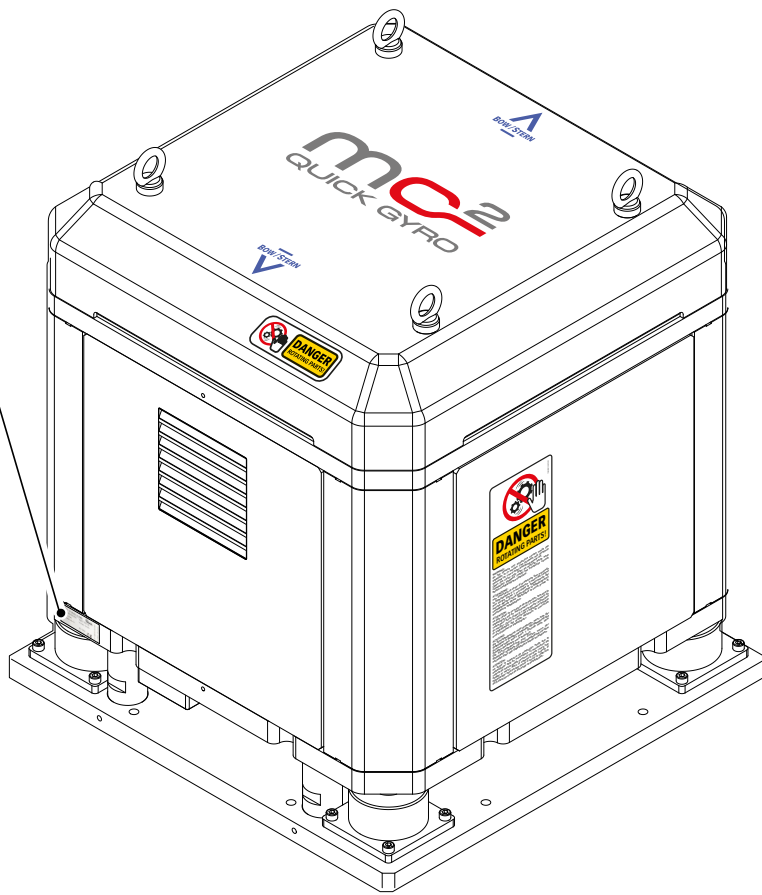



* **WARNING:** IN ORDER TO ACTIVATE QUICK WARRANTY, AN INSTALLATION VALIDATION AND THE FIRST START-UP (COMMISSIONING) MUST BE CARRIED OUT BY QUICK AUTHORIZED PERSONNEL ONLY.



9.0 - Introduction

This section describes the first start-up of the stabilizer.



Before you start, follow the indicated sequence to properly execute the mechanical and electrical installation operations described in the previous sections.



Before the start-up, the protections that had been previously removed must be put back in place, and the area surrounding the stabilizer must be cleared of personnel and equipment.

9.1 - Start-up instructions

Switch on the stabilizer via the **MC² RC Remote Control panel** (refer to the **MC² RC Remote Control Panel** user's manual).



10 - Maintenance

10.0 - Introduction

Quick MC² gyro stabilizers are built with materials resistant to the marine environment. Maintenance is however mandatory, even if no problems occur.

Quick® recommends a **periodical inspection every 2000 hours and an annual one.**

10.1 - Warnings



• Before any maintenance operation **disconnect the power supply and make sure that the FLYWHEEL HAS COMPLETELY STOPPED.**



• The warranty does not cover, under any circumstances, damages to property/ people, in the event that maintenance (of any type) is carried out before the stabilizer is disconnected from the power supply and the mass is completely still.



• Restore the power supply only after having correctly refitted all the safety devices that were previously removed.



10.2 - Periodic Maintenance

Periodic maintenance, **every 2000 hours**, must be performed by personnel authorized by **Quick®**. The Remote Control alerts, through a window (image below) that **periodic maintenance** must be performed.

The window appears in the middle of the screen. To close, press OK.

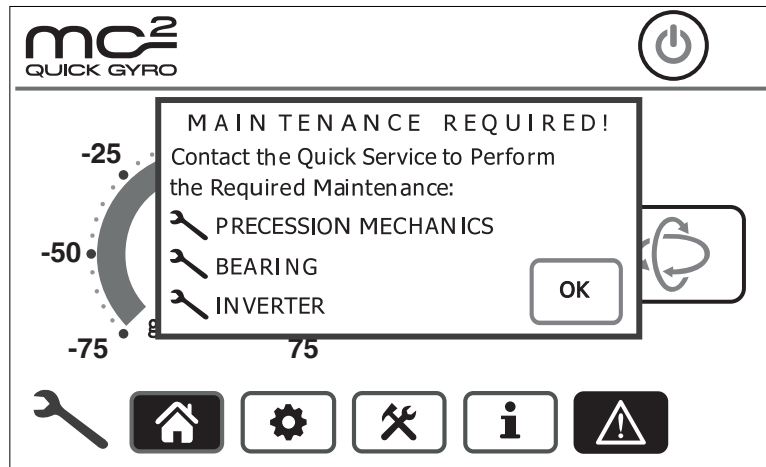

 The wrench icon remains visible until maintenance is performed; despite the maintenance notice, the stabilizer will continue to operate.

Active maintenance notification

-  • Contact the **Quick® service** to perform maintenance as soon as possible.
- In the event of problems with the machine due to lack of maintenance, the warranty is void during the notification period and **Quick®** assumes no liability for any problems with the **MC²**.
- Once maintenance has been performed by a **Quick®** technician, the icon will be reset.

Periodic maintenance table

SYSTEM / COMPONENT	ACTIVITY	PERIODIC
BEARINGS	CONTACT THE QUICK TECHNICAL SERVICE	EVERY 2000 HOURS
INVERTER	CONTACT THE QUICK TECHNICAL SERVICE	EVERY 2000 HOURS
PRECESSION	CONTACT THE QUICK TECHNICAL SERVICE	EVERY 2000 HOURS



10.3 - *Annual Maintenance

*** WARNING: THIS OPERATION MUST BE CARRIED OUT BY QUICK AUTHORIZED PERSONNEL ONLY. REMOVING THE COVERS AND SEALS WILL VOID THE QUICK WARRANTY.**



STRICTLY OBSERVE ALL PRECAUTIONS INDICATED IN THE MANUAL IN ORDER NOT TO DAMAGE YOURSELF AND THE STABILIZER.
IF IN DOUBT, CONTACT YOUR NEAREST "QUICK®" DEALER.

There are no indications/warnings via the RC Remote Control.

Refer to the annual maintenance chart below.

Annual maintenance table

SYSTEM / COMPONENT	ACTIVITY	PERIODIC
MECHANICAL	CHECK THE STABILIZER FOR CORROSION OR RUBBING MARKS. (FIGURE A)	ANNUAL
ELECTRICAL	CHECK THE CONNECTORS FOR CORRECT FIXING AND THE PRESENCE OF OXIDE.	ANNUAL
HYDRAULIC	REMOVE THE TOP COVER AND CHECK FOR OIL LEAKS. (FIGURE B)	ANNUAL
FIXING	CHECK THAT THE SCREWS FIXING THE STABILIZER TO THE HULL ARE TIGHTENED CORRECTLY (FIGURE C). THE VALUES ARE INDICATED ON PAGE 11	ANNUAL

Maintenance table (5 years) - only Quick authorized technicians

SYSTEM / COMPONENT	ACTIVITY	PERIODIC
MECHANICAL	Replace silent block and precession sensor belt	5 years

Use the torque wrench to tighten the bolts.
Refer to Nm on page 11

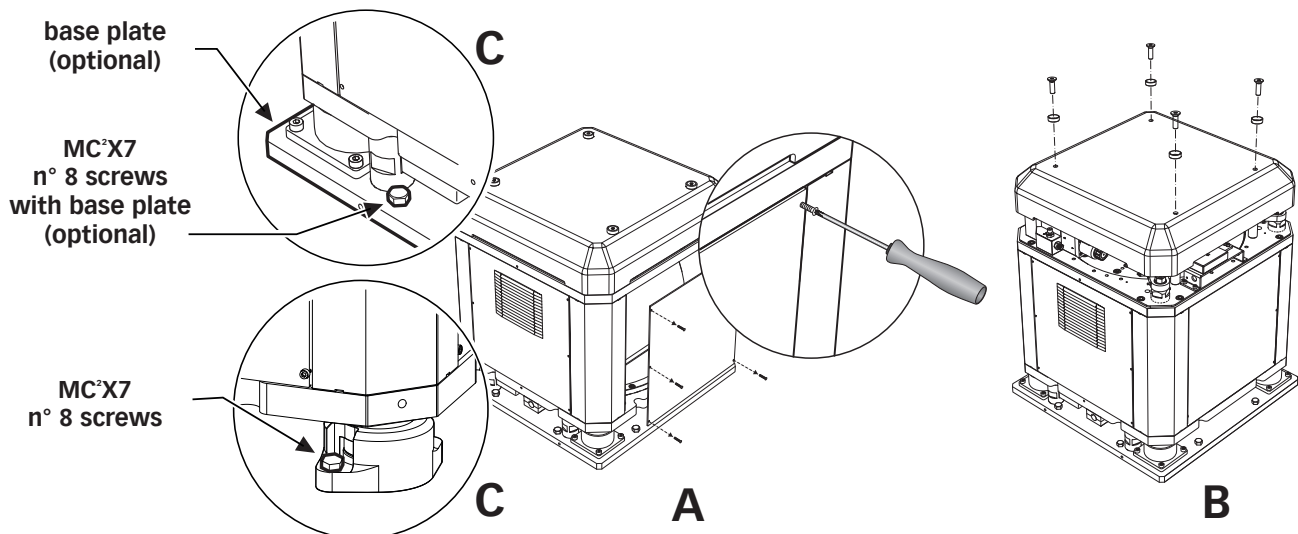

10.4 - External Cleaning

Clean the stabilizer with a soft cloth dampened with water; do not use chemicals or abrasives.

11.0 - Scrapping

The machine should be scrapped adopting safety measures that take account of the logistic and environmental conditions and the state of wear.

In general it is necessary to realise the demolition following the subsequent indications:

- The operator has to dress up protecting clothes and accessories (helmet, anti-accident shoes, gloves, possibly eyeglasses and mask) homologated following the anti-accident norm on force.
- Make sure that the machine has been disconnected form all power sources.
- Check that the hydraulic, pneumatic and water systems (including the accumulators) are completely empty. Drain if necessary.



It is forbidden to disperse the exhausted liquid in the environment, because it causes pollution.

- Check all pressurised systems, depressurising them if necessary.
- Break down the machine into easily transportable units.



The demolition of the machine must be assigned to companies specialized and trained to execute this kind of operations.



11 - Scrapping and Disposing

11.1 - Disposing

As a minimum, the following rules must be observed when scrapping the machine.

- The operator has to dress up protecting clothes and accessories (helmet, anti-accident shoes, gloves, possibly eyeglasses and mask) homologated following the anti-accident norm on force.
- The pieces of different nature (steel, aluminium, rubber, electric cables) should be separated indifferent containers.



Take great care when retrieving or separating the potentially hazardous materials used in the manufacture of the various machine components.

For the elimination of the contaminating substances(plastic materials, lubricating oil and syntethic rubber)respect the prevailing law disposition in the countryof the platform demolition.



Specialist waste disposal companies can be engaged to perform these tasks.



Remote Control

DESCRIPTION	CODE
RC REMOTE CONTROL MC ² X7 5" TOUCH IP66	FQRCMC25690A00

Remote Control Accessories

DESCRIPTION	CODE
CONNETTOR CABLE CAN T 5P F/F/F	FQCNCFFFR000A00
CONNETTOR CABLE CAN 5P F/F	FQCNCFFOR000A00
TERMINATOR CAN M M12	FQTNCANM1200A00





REV 002A | CE

MARCH 2020
INSTALLATION AND USE MANUAL

ANTI-ROLL GYRO STABILIZERS

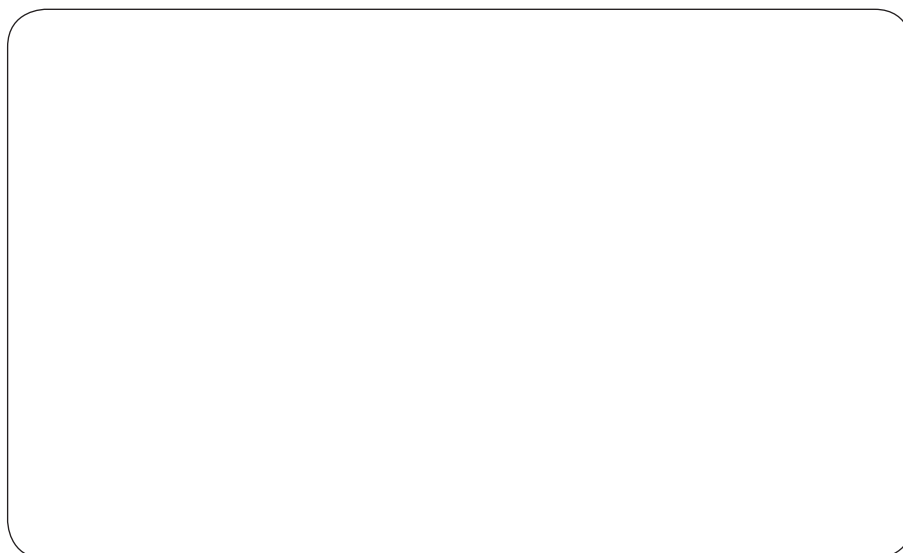

Product code and serial number



QUICK® S.p.A. - Via Piangipane, 120/A - 48124 Piangipane (RAVENNA) - ITALY
Tel. +39.0544.415061 - Fax +39.0544.415047 - www.quickitaly.com - quick@quickitaly.com