

Position Monitored Ball Valves

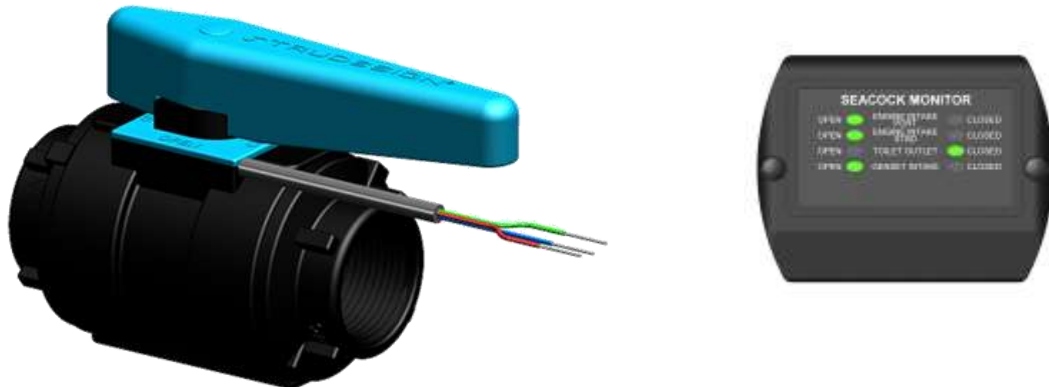

TRUDESIGN™ Certified Ball Valves are specifically designed for use in marine applications above and below the water line.

- Certified to ISO 9093-2 by the International Marine Certification Institute (IMCI, Belgium) when fitted to TRUDESIGN™ Skin Fittings (Thru Hulls)
- Comply with ABYC H-27 standards when used in conjunction with the TRUDESIGN™ ABYC collar and Skin Fittings (Thru Hulls).
- Certified by Bureau Veritas to ISO 9093-2.

Features:

- Allows remote monitoring of up to four Ball Valves (per seacock display panel) in the open or closed position.
- Can be wired into or part of an engine or generator start “interlock” to ensure they don’t start without cooling water available.
- Manufactured from a glass-reinforced Nylon composite – High strength, tough and light weight.
- Immune to corrosion & electrolysis – No corrosion breakages, increased safety.
- Electrically non-conductive. No electrical bonding.
- Suitable for use on all hull types - aluminium, steel, wood or FRP.
- The ball and sealing rings utilise a PTFE polymer to ensure a smooth action and minimal fouling of the internal ball.
- Can be “locked” in the closed position to comply with toilet waste outlet regulations. US Coast Guard Regulation 33 CFR 159.7 and ISO Standard 8099 for locking of toilet waste outlets
- Large operating temperature range – From -40°C to +110°C (for Ball Valve only)
- Available in both BSP and NPS thread forms
- U.V resistant – Will not degrade or discolour from the sun’s ultraviolet rays.
- 100% leak tested before leaving factory.

Features Continued

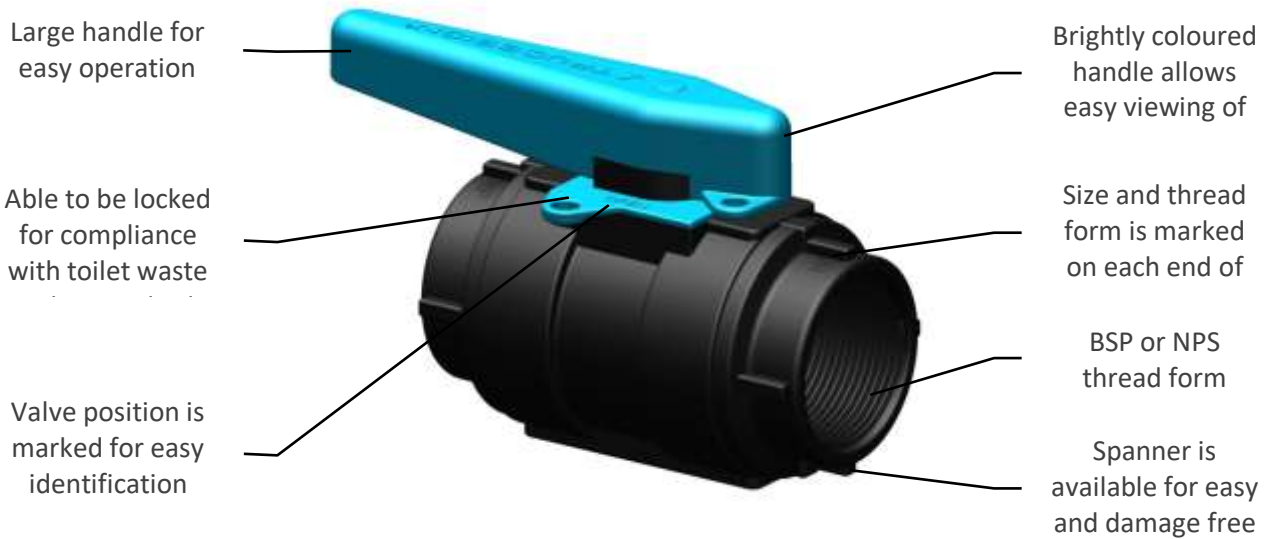

Models

Internal diameter	BSP Thread	
	Part #	Description
19mm [¾"]	90473	Ball Valve Position Monitored ½" BSP
	90277	Ball Valve Position Monitored ¾" BSP
	90243	Ball Valve Position Monitored 1" BSP
32mm [1¼"]	90239	Ball Valve Position Monitored 1¼" BSP
	90236	Ball Valve Position Monitored 1½" BSP
52mm [2"]	90474	Ball Valve Position Monitored 2" BSP

Internal diameter	NPS Thread	
	Part #	Description
19mm [¾"]	91219	Ball Valve Position Monitored ½" NPS
	91220	Ball Valve Position Monitored ¾" NPS
	91221	Ball Valve Position Monitored 1" NPS
32mm [1¼"]	91222	Ball Valve Position Monitored 1¼" NPS
	91223	Ball Valve Position Monitored 1½" NPS
52mm [2"]	91224	Ball Valve Position Monitored 2" NPS

Ball Valves are supplied with spanner and installation instructions

Weight

Internal Diameter	Thread Size	Weight (g)	Weight (oz)
19mm [¾"]	½", ¾", 1"	350	12.3
32mm [1¼"]	1¼", 1½"	500	17.6
52mm [2"]	2"	750	26.4
90412 Panel Display Ball Valve		230	8.1

Display Panel

- The Ball Valve Display Panel is supplied with the following;
 - Installation instructions
 - 2 x hook-up wire with connector – 2.5m (8.2')
 - Mounting screws and covers
 - Sticker Sheet with the following options

AIRCON INTAKE	ENGINE INTAKE	HOLDING TANK OUTLET PORT	TOILET INTAKE STABD
BAIT TANK INTAKE	ENGINE INTAKE PORT	HOLDING TANK OUTLET STBD	TOILET OUTLET
BLACK WATER OUTLET	ENGINE INTAKE STBD	SALTWATER WASH INTAKE	TOILET OUTLET AFT
BLACK WATER OUTLET AFT	GENSET INTAKE	TOILET INTAKE	TOILET OUTLET FWD
BLACK WATER OUTLET FWD	HOLDING TANK OUTLET	TOILET INTAKE AFT	TOILET OUTLET PORT
BLACK WATER OUTLET PORT	HOLDING TANK OUTLET AFT	TOILET INTAKE FWD	TOILET OUTLET STBD
BLACK WATER OUTLET STBD	HOLDING TANK OUTLET FWD	TOILET INTAKE PORT	WATERMAKER INTAKE

The Position Monitoring function switches state when the Ball Valve is in the open position.



BLUE = Valve closed signal
RED = Supply (9 - 15V)
GREEN = Valve open signal

Supply voltage 9.0 – 15V DC
 Maximum switching current – 500mA
 Wire length – 2m (6.5')

Part #	Description
90412	Panel Display Ball Valve

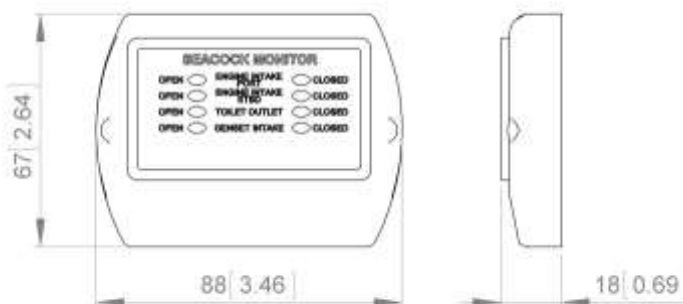

Thread Sealing

Ensure the skin fitting (Thru Hull) and ball valve location enables full operation of the valve handle. See also our info sheet on TRUDESIGN™ skin fitting installation. The following sealing methods can be used

- 3M™ Marine Adhesive Sealant Fast Cure 5200. A one-part polyurethane adhesive/sealant. Starts to cure (tack-free) in approximately 2 hours, after which hoses can be attached. Full cure takes 24 hours – refer to manufacturer’s product literature.
- SIKAFLEX® 291i and 591 Marine Sealants. Refer to manufacturer’s product literature.
- Bostik® 920 Marine Sealant. A one-part urethane adhesive/sealant. Starts to cure (tack-free) in approx. 2 hours, after which hoses can be attached. Full cure takes 1.5 – 3 days – refer to manufacturer’s product literature.
- 3M™ Marine Adhesive Sealant Fast Cure 4200 is approximately half the strength (once cured) of 3M 5200 which allows for eventual disassembly of the ball valve from skin fitting.
- LOCTITE® 5331 A one-part acetoxy silicone sealant. Starts to cure (tack-free) in approx. 10 minutes, after which hoses can be attached. Full cure is achieved within 12 hours (at min. 40% atmospheric humidity) – refer to product literature. Creates a permanent seal for threaded connections.
- PTFE (Teflon) Thread Tape is a traditional thread sealing method which provides a good seal when applied correctly. However, in some cases if the position or tightness of the Ball Valve is incorrect, it will need to be unscrewed and more tape applied, slowing the assembly process. Additionally, the fittings can sometimes be turned by hand after being installed.
- LOCTITE® 55 Pipe Sealing Cord is a coated multi-filament cord designed as a faster method than Teflon tape to seal threaded fittings. The main advantage is that a component, for example a Ball Valve, could be screwed down then screwed back a turn to suit positioning whilst still maintaining a tight seal. This eliminates the need to remove the entire Ball Valve and apply more tape as with traditional Teflon tape.

Fitting

Screw ball valve onto the skin fitting (Thru Hull) using the correct Ball Valve Spanner (available from TRUDESIGN™), or other appropriate tool. Tighten to a maximum of 16Nm (12ft/lbs).

Check that the final position of the Ball Valve is such that it allows full movement of the handle from the open to closed position, and that it is clear of objects which may cause inadvertent operation.

Note: The connecting threads on each end of the Ball Valves are a parallel thread form. The advantage of parallel threads over tapered is that there is maximum engagement between the mating threads providing a strong and watertight seal. This is also a requirement to meet international marine standards.

Mixing parallel and tapered threads can cause strength and sealing problems as the engagement can frequently be only a few turns

Replacement “T” and “Lever” Handles

Part #	Description
91038	Replacement “ T ” handle Small – 25mm,19mm,13mm (1”, ¾”, ½”)
91040	Replacement ‘T’ Handle Large – 50mm-38mm-32mm (2”, 1½”, 1¼”)
91155	Replacement Lever Handle Small 25mm-19mm-13mm (1”, ¾”, ½”)
91156	Replacement Lever Handle Large 50mm-38mm-32mm (2”, 1½”, 1¼”)



Ball Valve Spanner

90476	Spanner / Wrench Ball Valve ½” PKG
90477	Spanner / Wrench Ball Valve ¾” & 1” PKG
90478	Spanner / Wrench Ball Valve 1¼” & 1½” PKG
90479	Spanner / Wrench Ball Valve 2” PKG



Ball Valve Handle Tag – Identification Tags are available that easily fit onto the Lever Handles. See Separate Product Information Sheet.



Dimensions

A	B		C		D		E		F		Lever Handle				T-Handle	
	Size	Length		Length		Height		Width		Minimum Internal ϕ		G		H		I
1/2"	25	1	102mm	4	88mm	3 4/9"	61mm	2 3/8"	20mm	3/4"	32mm	1 1/4"	93mm	3 2/3"	50mm	2
3/4"	22mm	6/7"	102mm	4	88mm	3 4/9"	61mm	2 3/8"	20mm	3/4"	32mm	1 1/4"	93mm	3 2/3"	50mm	2
1"	22mm	6/7"	102mm	4	88mm	3 4/9"	61mm	2 3/8"	20mm	3/4"	32mm	1 1/4"	93mm	3 2/3"	50mm	2
1 1/4"	32mm	1 1/4"	122mm	4 4/5"	102mm	4	76mm	3	32mm	1 1/4"	38mm	1 1/2"	108mm	4 1/4"	57mm	2 1/4"
1 1/2"	32mm	1 1/4"	122mm	4 4/5"	102mm	4	76mm	3	32mm	1 1/4"	38mm	1 1/2"	108mm	4 1/4"	57mm	2 1/4"
2"	32mm	1 1/4"	141mm	3	124mm	4 6/7"	99mm	3 7/8"	48mm	1 8/9"	38mm	1 1/2"	108mm	4 1/4"	57mm	2 1/4"

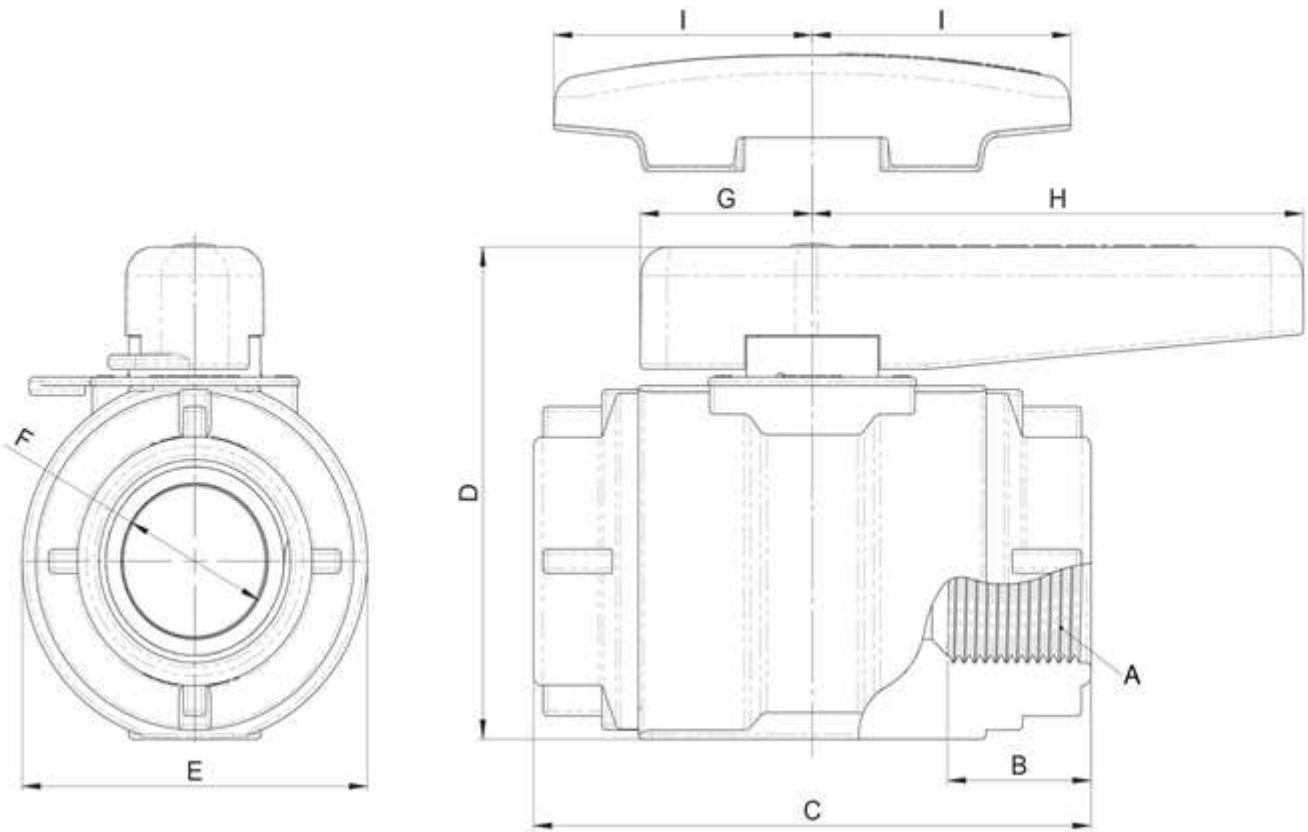

The information contained in this information sheet is for general information purposes only. The information is provided by TruDesign™ and while we endeavour to keep the information up to date and correct, we make no representations or warranties of any kind, express or implied, about the completeness, accuracy, reliability, suitability or availability. Any reliance you place on such information is therefore strictly at your