

# N4.140E SD

## SPECIFICATIONS



Power at crankshaft	99.4 kW [135 hp]	Engine base	Kubota
Displacement	3.769 l [230 in <sup>3</sup> ]	Fuel system	Electronic injection
Configuration	4 cylinders in line	Air intake	Turbocharged with intercooler
Operation type	4 strokes Diesel	Cooling	Closed cooling with heat exchanger
Bore & Stroke	100 x 120 mm [3.94 x 4.72 in]	Max mounting angle	7° Front down 7° Front up
Compression ratio	19.1 : 1	Alternator	12 Volt 120 Amp
Rated speed	2600 rpm	Rating	M4
Idling speed	825 rpm	Emission compliance	RCD 2013/53/EU EPA marine Tier 3 BSO 2
Peak torque	453.6 Nm	Dry weight	353 kg [778 lbs]
Peak torque speed	1600 rpm		

# N4.140E SD

99.4 kW [135 hp] at 2600 rpm

## TECHNICAL DESCRIPTION

### ENGINE BLOCK

- 4 Cylinders in line
- 4 Valves per cylinder
- Gear driven valve train
- Watercooled exhaust manifold

### FUEL SYSTEM

- Electronic governor
- Cam driven in-line injection pump
- Fuel feed pump
- Fuel filter with hand primer

### LUBRICATION SYSTEM

- Replaceable full-flow oil filter
- Oil dipstick
- Oil drain pump

### COOLING SYSTEM

- Closed cooling with heat exchanger
- Gear driven self-priming raw water pump
- Coolant circulating pump
- Water cooled exhaust elbow

### ELECTRICAL SYSTEM & INSTRUMENTATION

- 12 V Electrical system
- 12 V / 120 A alternator
- Electric starter motor
- Electric stop function
- Instrumentation panel, including Start/ Stop, tachometer, coolant temperature & oil pressure indicators, alarms
- Extension cable harness with plug-and-play

### AIR INTAKE

- Turbocharged with intercooler
- Mounted air cleaner

### OTHER FEATURES

- Flexible engine mounting
- Bracket for control cables

### OPTIONAL EQUIPMENTS & ACCESSORIES

- Keel cooling adaptation
- Complete marine propulsion systems
- Throttle and shift controls
- Additional instrumentation, Flying bridge extension harness
- Alternator 24 V - 55 A
- 24 V Electrical system
- Engine mounting adaptation
- Two pole electrical system
- Complete exhaust systems
- Trolling valve

### RATINGS

- Up to 1000 annual operating hours
- Load factor up to 35%
- Full power for no more than 30 minutes out of each 8 hours of operation. The remaining time must be at, or below cruising speed

### TRANSMISSIONS

- SD 15 - Standard or extended leg.

## PERFORMANCE CURVES

### POWER AT CRANKSHAFT

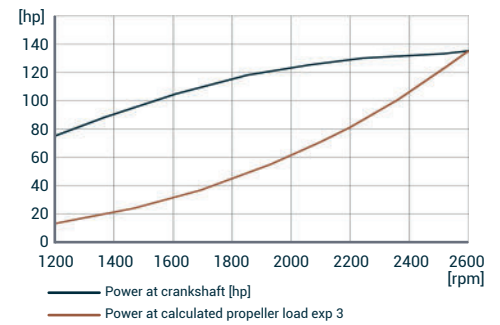

### TORQUE AT CRANKSHAFT

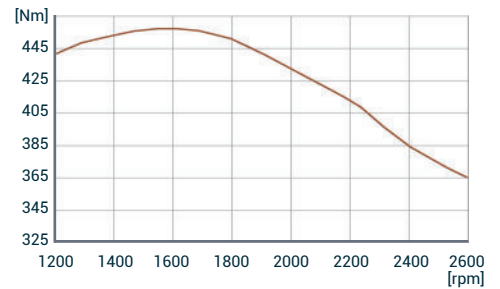

### FUEL CONSUMPTION

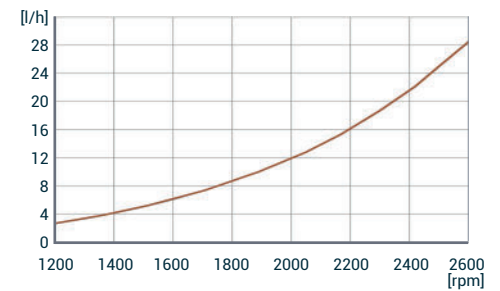

## DIMENSIONS

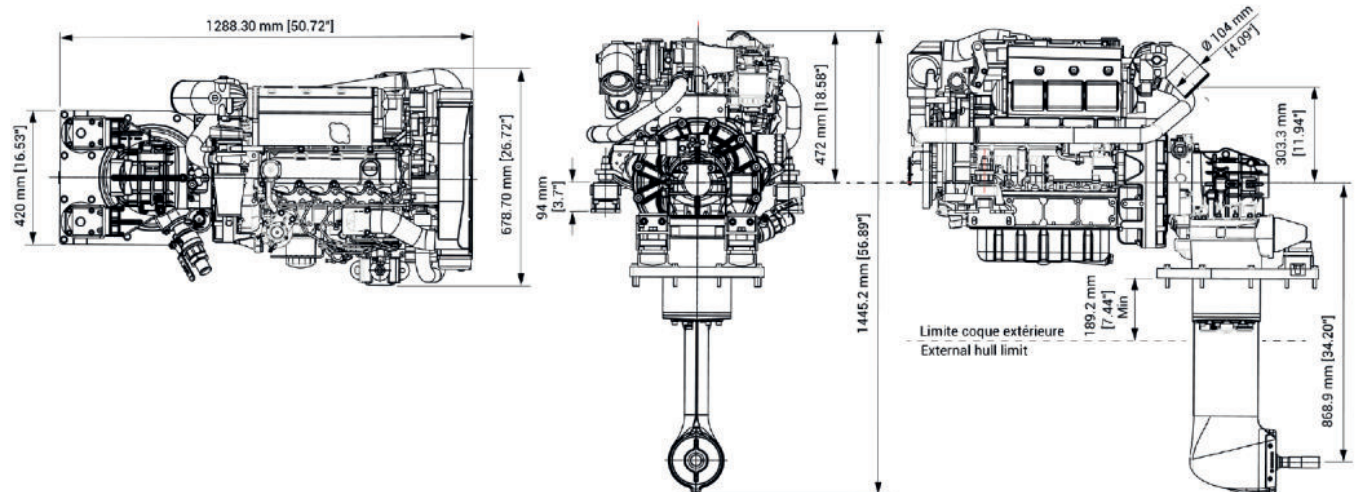

**NANNI INDUSTRIES S.A.S.**  
11, Avenue Abbé Mariotte  
33260 La Teste - France  
Tel +33 (0)5 56 22 30 60  
[www.nannienergy.com](http://www.nannienergy.com)

**NANNI SRL**  
Via degli Olmetti, 44/A  
00060 Formello - Roma - Italia  
Tel +39 06 30 88 42 51  
[www.nannienergy.com](http://www.nannienergy.com)

Technical data according to ISO 8665. This document is not contractual. Nanni reserves the right to modify any of the characteristics stated in this document without notice, in a constant effort to improve the quality of its products. Images and illustrations may show non standard equipments. All combination of equipment & accessory are not available.

DGBXXC01069B