

MARINE PRODUCT DATA SHEET

OEM: 8050-305-526

AFTERMARKET: 8050-305-526

APPLICATION

12V DC Oil change, winterizing, automatic transmission fluids, anti-freeze solutions, low viscosity gear and liquid transfer. Other uses may include 12 VDC pressurized water systems.

PUMP:

Type: 3 Chamber Diaphragm
Ports: 3/8" NPT-F.
Liquid: 180 °F [82 °C] Max
Dry-Prime: 6 feet [1.82 M]
Inlet PSI: 30 PSI [2.1 Bar] Max
Run Dry: Yes



ELECTRICAL:

Motor: 12VDC Permanent Magnet, Continuous Duty
Protection: Thermal Overload, Automatic Restart
Leads: 16 AWG, 16" [40 cm] Red +, 13" [33 cm] Black -
Fuse: 7.5 Amp Recommended
Control: 30 PSI Internal By-pass

Incorporating SHURflo's advance motor technology that includes thermal overload protection, these pumps are self-priming, easy to install and are extremely versatile-perfect for a variety of uses including winterizing, Oil changing and liquid transfer.

MATERIALS:

Housing: Nylon
Valves: Buna
Diaphragm: Geolast
Hardware: Stainless Steel

APPROVALS:

Ignition Protection 8846, CE

SHIPPING:

Approx. Net Weight: 4 Lbs. [1.8 Kg]
Carton Quantity: 6
Approx. Carton Weight: 28 Lbs. [12.7 Kg]

Approx. Carton Size:
24"L x 18"W x 6"H
[61cm x 46cm x 15cm]

RELATED DOCUMENTS:

Catalog: MS-030-140
Applications Spec Guide: MS-020-005
Installation Manual: 911-714
Aftermarket Warranty: 911-1045

Parts Kits

| Number | Components | Parts Kits |
|--------|----------------|--------------|
| 9 | Motor | 94-11-148-06 |
| 5a | Valve Assembly | 94-391-12 |
| 8 | Drive Assembly | 94-385-42 |

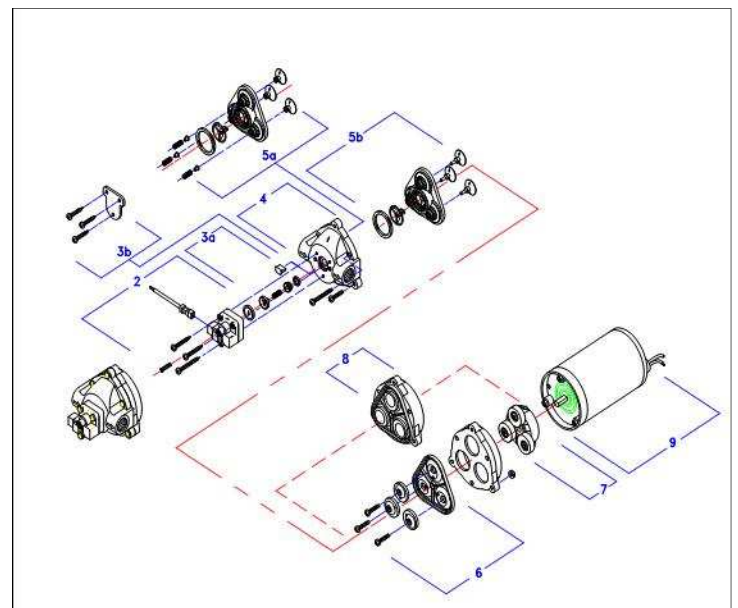

TYPICAL PERFORMANCE WITH WATER

| PRESSURE | | FLOW | | CURRENT |
|----------|-----|------|------|---------|
| BAR | PSI | GPM | LPM | AMPS |
| 0.0 | 0 | 1.55 | 5.86 | 2.2 |
| 0.7 | 10 | 1.45 | 5.48 | 2.8 |
| 1.4 | 20 | 1.36 | 5.14 | 3.5 |
| 2.1 | 30 | 1.10 | 4.16 | 4.1 |
| 2.8 | 40 | 0.15 | 0.56 | 4.4 |

TYPICAL MOTOR SHELL T-RISE @ 40 PSI, 12V

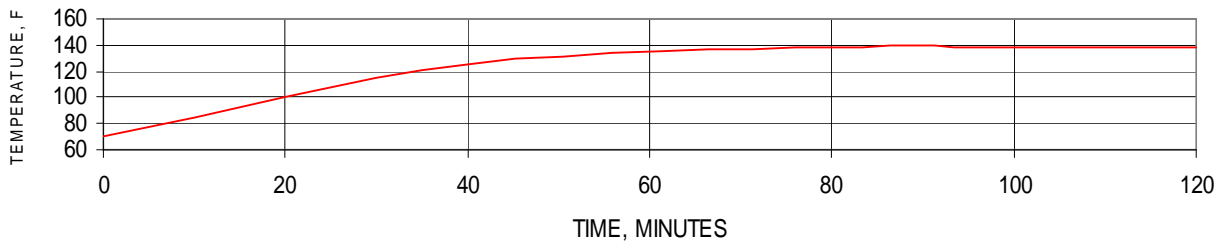

DIMENSIONS [mm]

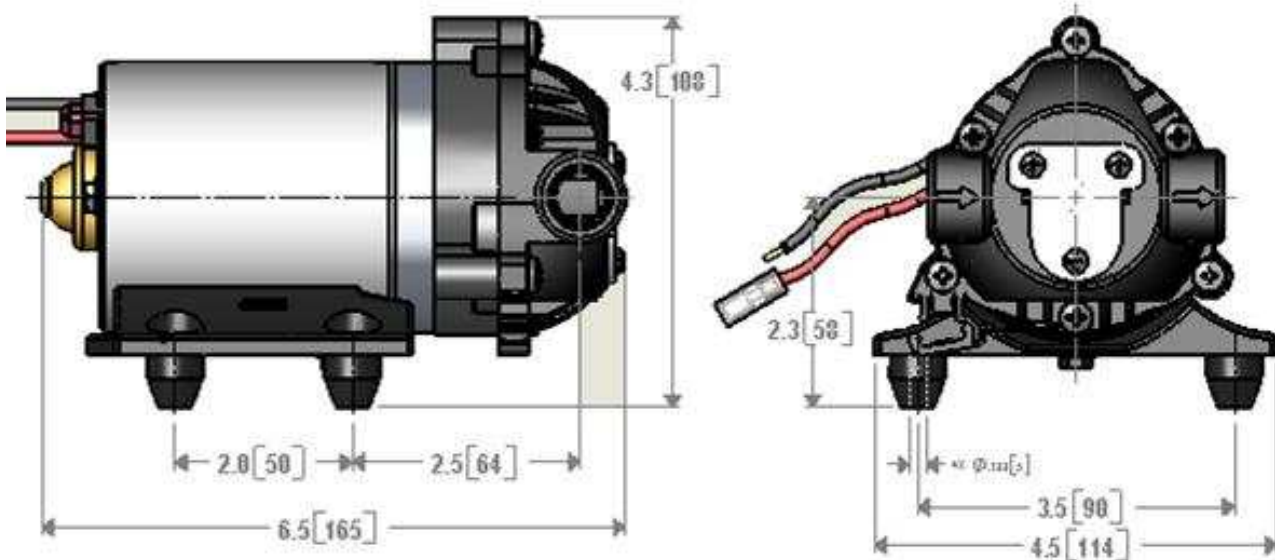

WATER PURIFICATION

3545 Harbor Gateway South, Suite 103, Costa Mesa, CA 92626, (800) 854-3218 www.SHURFLO.com

All Pentair trademarks and logos are owned by Pentair, Inc. All other brand or product names are trademarks or registered marks of their respective owners. Because we are continuously improving our products and services, Pentair reserves the right to change specifications without prior notice. Pentair is an equal opportunity employer.